

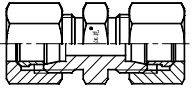

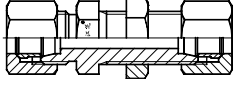

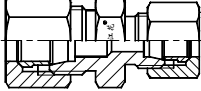

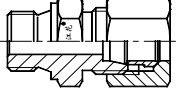
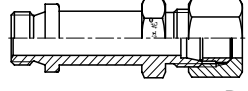
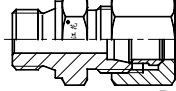
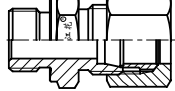
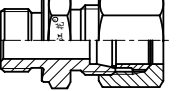
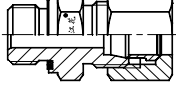
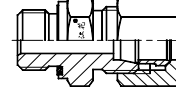
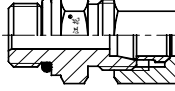
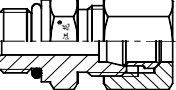
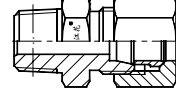

	<p><b>G2U</b> 直通中间接头 Union Straight</p>  <p>Page 6</p>	<p><b>G2BU</b> 隔壁直通管接头 Bulkhead Union Straight</p>  <p>Page 6</p>	<p><b>G2UR</b> 直通变径接头 Union Reducer</p>  <p>Page 7</p>
<p><b>G2MCMA</b> 端直通接头—公制螺纹 Male Connector—M-A</p>  <p>Page 8</p>	<p><b>G2LMCMA</b> 端直通长管接头—公制螺纹 Long Male Connector—M-A</p>  <p>Page 9</p>	<p><b>G2MCGA</b> 端直通接头—英制螺纹 Male Connector—BSPP(G)-A</p>  <p>Page 10,11</p>	<p><b>G2MCMB</b> 端直通接头—公制螺纹 Male Connector—M-B</p>  <p>Page 12</p>
<p><b>G2MCGB</b> 端直通接头—英制螺纹 Male Connector—BSPP(G)-B</p>  <p>Page 13,14</p>	<p><b>G2LMCME</b> 端直通接头—M-E Male Connector—M-E</p>  <p>Page 15</p>	<p><b>G2MCGE</b> 端直通接头—英制螺纹 Male Connector—BSPP(G)-E</p>  <p>Page 16,17</p>	<p><b>G2MCMF</b> 端直通接头—公制螺纹 Male Connector—M-F</p>  <p>Page 18</p>
<p><b>G2MCFU</b> 端直通接头—UN/UNF螺纹 Male Connector—UN/UNF-F</p>  <p>Page 19</p>	<p><b>G2LMCZ</b> 端直通接头—米制锥螺纹 Male Connector—ZM Thread</p>  <p>Page 19</p>	<p><b>G2MCR</b> 端直通接头—英制锥螺纹 Male Connector—BSPT Thread</p>  <p>Page 20</p>	<p><b>G2MCN</b> 端直通接头—NPT螺纹 Male Connector—NPT Thread</p>  <p>Page 21,22</p>
<p><b>G2LMCN</b> 端直通长管接头—NPT螺纹 Long Male Connector—NPT Thread</p>  <p>Page 23</p>	<p><b>G2WC</b> 焊接直通管接头 Butt-Welding Connector</p>  <p>Page 24</p>	<p><b>G2WBU</b> 焊接隔壁管接头 Weld Bulkhead Union</p>  <p>Page 24</p>	<p><b>G2FCM</b> 直通内螺纹接头—公制螺纹 Female Connector—M Thread</p>  <p>Page 25</p>
<p><b>G2FCG</b> 直通内螺纹接头—BSPP螺纹 Female Connector—BSPP Thread</p>  <p>Page 25</p>	<p><b>G2FCN</b> 直通内螺纹接头—NPT螺纹 Female Connector—NPT Thread</p>  <p>Page 26</p>	<p><b>G2GAM</b> 压力表接头—M螺纹 Gauge Adapters—Metric Thread</p>  <p>Page 26</p>	<p><b>G2GAG</b> 压力表接头—BSPP(G)螺纹 Gauge Adapters—BSPP(G) Thread</p>  <p>Page 27</p>
<p><b>G2AGAG</b> 对接压力表接头—BSPP螺纹 Adjustable Gauge Adapters—BSPP</p>  <p>Page 27</p>	<p><b>G2AMCME</b> 端直通组合接头—M螺纹 Adjustable Male Connector—M-E</p>  <p>Page 28</p>	<p><b>G2AMCGE</b> 端直通组合接头—BSPP(G)螺纹 Adjustable Male Connector—BSPP-E</p>  <p>Page 28</p>	<p><b>G2AMCMF</b> 端直通组合接头—M螺纹 Adjustable Male Connector—M-E</p>  <p>Page 29</p>
<p><b>G2AMCN</b> 端直通组合接头—NPT螺纹 Adjustable Male Connector—NPT</p>  <p>Page 29</p>	<p><b>G2AUR</b> 组合变径接头—带密封锥体 Adjustable Union Reducing</p>  <p>Page 30,31</p>	<p><b>G2SU</b> 组合直通接头—双侧带密封锥体 Swivel Union—with Taper</p>  <p>Page 32</p>	<p><b>G2SUR</b> 组合变径接头—双侧带密封锥体 Swivel Union Reducer—with Taper</p>  <p>Page 32,33</p>

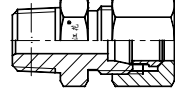
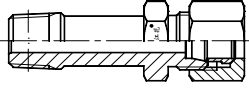
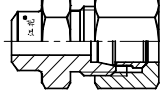
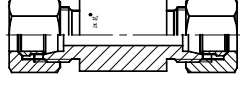
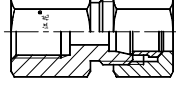
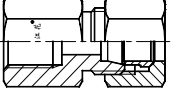
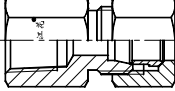
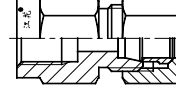
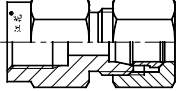
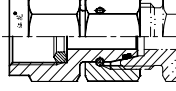
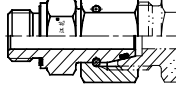
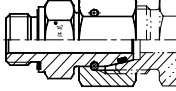
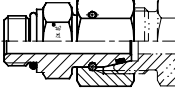
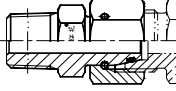
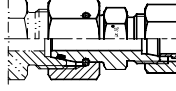
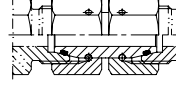
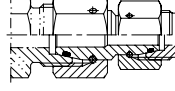
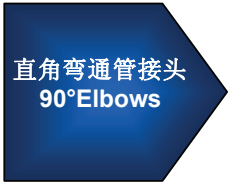
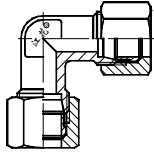
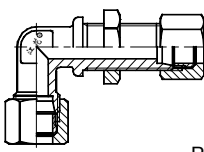
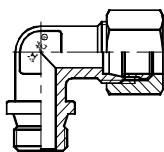
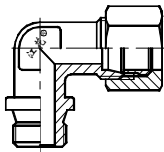
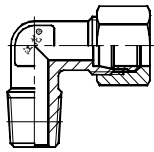
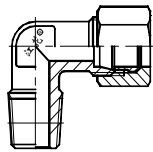
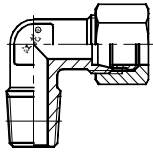
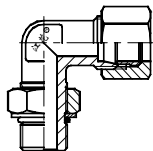
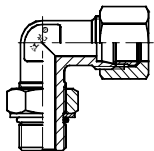
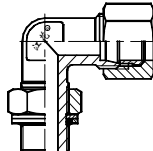
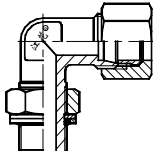
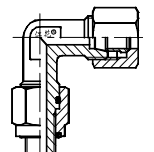
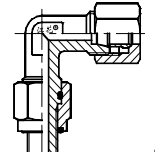
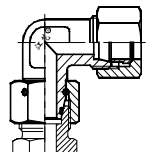
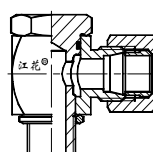
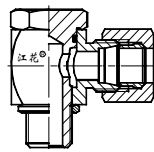
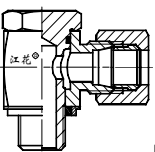
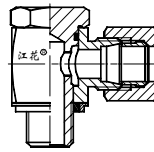
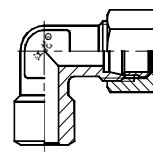
 <p>直角弯通管接头 90°Elbows</p>	<p><b>G2E</b> 直角管接头 Union Elbow</p>  <p>Page 34</p>	<p><b>G2BUE</b> 隔壁直角管接头 Bulkhead Union Elbow</p>  <p>Page 34</p>	<p><b>G2MEMA</b> 端直角管接头—公制螺纹 Male Elbow—M-A</p>  <p>Page 35</p>
<p><b>G2MEGA</b> 端直角管接头—BSPP(G)螺纹 Male Elbow—G-A</p>  <p>Page 35</p>	<p><b>G2MEN</b> 端直角管接头—NPT螺纹 Male Elbow—NPT Thread</p>  <p>Page 36</p>	<p><b>G2MER</b> 端直角管接头—BSPT(R)螺纹 Male Elbow—BSPT(R) Thread</p>  <p>Page 36</p>	<p><b>G2MEZ</b> 端直角管接头—米制锥螺纹 Male Elbow—ZM Thread</p>  <p>Page 36</p>
<p><b>G2AMEMF</b> 可调向端直角管接头—公制螺纹 Adjustable Male Elbow—M-F</p>  <p>Page 37</p>	<p><b>G2AMEUF</b> 可调向端直角管接头—UN螺纹 Adjustable Male Elbow—UN/UNF-F</p>  <p>Page 37</p>	<p><b>G2AMEMH</b> 可调向端直角管接头—公制螺纹 Adjustable Male Elbow—M-H</p>  <p>Page 38</p>	<p><b>G2AMEGH</b> 可调向端直角管接头—BSPP螺纹 Adjustable Male Elbow—G-H</p>  <p>Page 38</p>
<p><b>G2AMEMO</b> 可调向端直角管接头—公制螺纹 Adjustable Male Elbow—M-O</p>  <p>Page 39</p>	<p><b>G2AMEGO</b> 可调向端直角管接头—英制螺纹 Adjustable Male Elbow—BSPP-O</p>  <p>Page 39</p>	<p><b>G2AUE</b> 组合直角管接头 Adjustable Union Elbow</p>  <p>Page 40</p>	<p><b>G2SHEM</b> 高压铰接式弯通接头—公制螺纹 Swivel High-Pressure Elbow Union—M</p>  <p>Page 41</p>
<p><b>G2SHEG</b> 高压铰接式弯通接头—英制螺纹 Swivel High-Pressure Elbow Union—G</p>  <p>Page 41</p>	<p><b>G2SHEME</b> 高压铰接式弯通接头—弹性密封 Swivel High-Pressure Elbow Union—ME</p>  <p>Page 42</p>	<p><b>G2SHEGE</b> 高压铰接式弯通接头—弹性密封 Swivel High-Pressure Elbow Union—GE</p>  <p>Page 42</p>	<p><b>G2BWE</b> 焊接弯通管接头 Butt-welding Elbow</p>  <p>Page 43</p>
 <p>三通管接头 Tees</p>	<p><b>G2T</b> 三通管接头 Union Tee</p>  <p>Page 43</p>	<p><b>G2MBTMA</b> 端分支三通管接头—公制螺纹 Male Branch Tee—M Thread</p>  <p>Page 44</p>	<p><b>G2MBTGA</b> 端分支三通管接头—BSPP螺纹 Male Branch Tee—BSPP Thread</p>  <p>Page 44</p>
<p><b>G2MRTMA</b> 端直路三通管接头—M螺纹 Male Run Tee—Metric Thread</p>  <p>Page 45</p>	<p><b>G2MRTGA</b> 端直路三通管接头—BSPP螺纹 Male Run Tee—BSPP Thread</p>  <p>Page 45</p>	<p><b>G2MBTN</b> 端分支三通管接头—NPT螺纹 Male Branch Tee—NPT Thread</p>  <p>Page 46</p>	<p><b>G2MRTN</b> 端直路三通管接头—NPT螺纹 Male Run Tee—NPT Thread</p>  <p>Page 46</p>

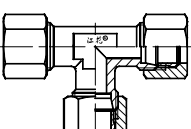
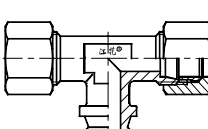
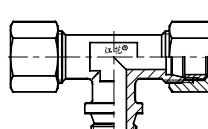
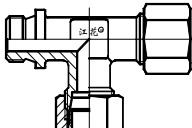
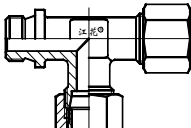
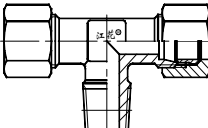
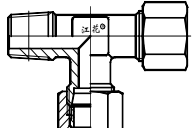
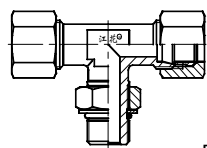
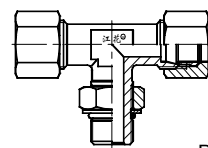
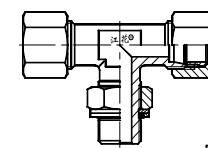
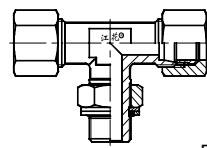
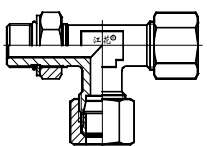
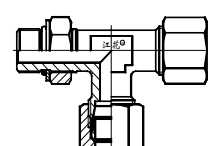
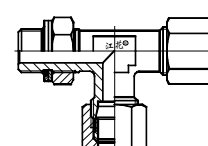
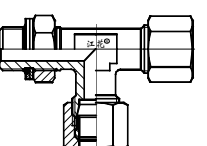
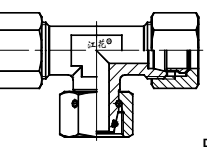
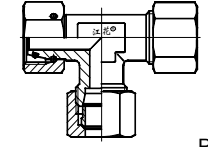
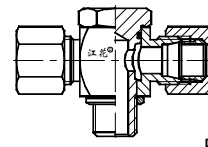
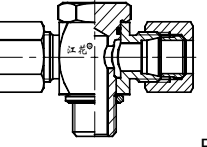
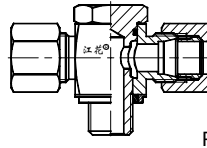
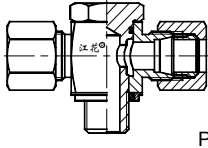
<p><b>G2AMBTMF</b> 可调端分支三通管接头—M螺纹 Adjustable Male Branch Tee—M-F</p>  <p>Page 47</p>	<p><b>G2AMBTUF</b> 可调端分支三通管接头—UN螺纹 Adjustable Male Branch Tee—UN/UNF</p>  <p>Page 47</p>	<p><b>G2AMBTMH</b> 可调端分支三通管接头—M螺纹 Adjustable Male Branch Tee—M-H</p>  <p>Page 48</p>	<p><b>G2AMBTGH</b> 可调端分支三通管接头—G螺纹 Adjustable Male Branch Tee—G-H</p>  <p>Page 48</p>
<p><b>G2AMRTMF</b> 可调端直路三通管接头—M螺纹 Adjustable Male Run Tee—M-F</p>  <p>Page 49</p>	<p><b>G2AMRTUF</b> 可调端直路三通管接头—UN螺纹 Adjustable Male Run Tee—UN/UNF</p>  <p>Page 49</p>	<p><b>G2AMRTMH</b> 可调端直路三通管接头—M螺纹 Adjustable Male Run Tee—M-H</p>  <p>Page 50</p>	<p><b>G2AMRTGH</b> 可调端直路三通管接头—G螺纹 Adjustable Male Run Tee—G-H</p>  <p>Page 50</p>
<p><b>G2ABT</b> 组合分支三通管接头 Adjustable Branch Tee</p>  <p>Page 51</p>	<p><b>G2ART</b> 组合直路三通管接头 Adjustable Run Tee</p>  <p>Page 52</p>	<p><b>G2SHTM</b> 高压铰接式三通管接头-M螺纹 Swivel High-Pressure Tee Union—M</p>  <p>Page 53</p>	<p><b>G2SHTG</b> 高压铰接式三通管接头-G螺纹 Swivel High-Pressure Tee Union—G</p>  <p>Page 53</p>
<p><b>G2SHTME</b> 高压铰接式三通管接头-弹性密封 Swivel High-Pressure Tee Union—M</p>  <p>Page 54</p>	<p><b>G2SHTGE</b> 高压铰接式三通管接头-弹性密封 Swivel High-Pressure Tee Union—G</p>  <p>Page 54</p>	<p>四通管接头 Cross</p> 	<p><b>G2C</b> 四通管接头 Union Cross</p>  <p>Page 55</p>
<p>管帽、堵头和附件 Caps, Plugs &amp; Accessories</p> 	<p><b>G2SS</b> 支撑套 Support Sleeve</p>  <p>Page 55</p>	<p><b>G2CAP</b> 管帽 Cap</p>  <p>Page 56</p>	<p><b>G2PL</b> 堵头 Plag</p>  <p>Page 56</p>
<p><b>G2M</b> 卡套螺母 M Nut</p>  <p>Page 57</p>	<p><b>G2CR</b> 卡套 Cutting Ring</p>  <p>Page 57</p>	<p>附录A: 油口和终端螺纹 Appendix A: Ports and Stud Ends</p> <p>Page: AA-1~AA-5</p>	

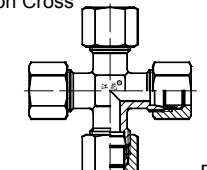
型号表示方法:

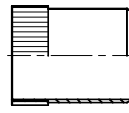
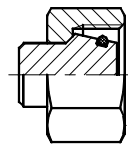
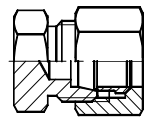
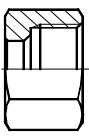
**MODEL NUMBER DESCRIPTION:**

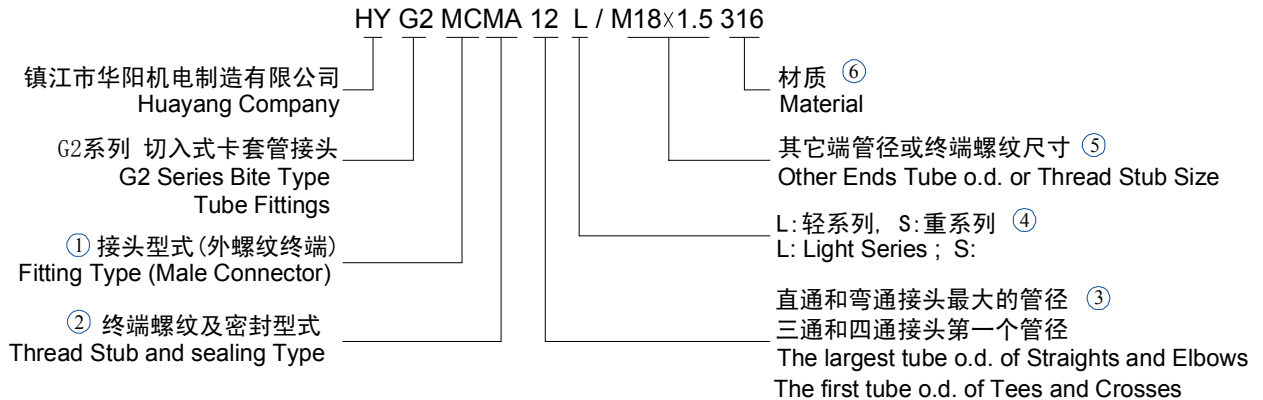

①接头型式表示方法: 一般为英文名称的缩写, 如:

The identification for Fitting Type: it's the abbreviation of English Name. Such as:

- U—直通管接头 Union
- E—直角管接头 Union Elbow
- C—四通管接头 Union Cross
- UR—直通变径管接头 Union Reducer
- BU—隔壁直通管接头 Bulkhead Union Straight
- BE—隔壁直角管接头 Bulkhead Union Elbow
- MC—端直通管接头 Male Connector
- ME—端直角管接头 Male Elbow
- FC—内螺纹直通管接头 Female Connector
- GA—压力表管接头 Gauge Adapter
- AMC—端直通组合接头 Adjustable Male Connector
- SHE—高压铰接式弯通接头 Swivel High-Pressure Elbow Union
- MBT—端分支三通管接头 Male Branch Tee
- MRT—端直路三通管接头 Male Run Tee
- 其它型式参照索引 Other types cross index.

**②终端螺纹型式 Thread Designations and Standards**

代码 Code	螺纹型式 Description	适用标准 Applicable Standards
<b>M</b>	米制螺纹 Metric Screw Threads	GB 193 ISO 261 ANSI B1.13M
<b>G</b>	BSPP管螺纹 British Standard Pipe (Parallel) Threads	GB 7307, ISO 228/1, BS 2779, JIS B0202
<b>U</b>	UN/UNF统一螺纹 Unified Threads	ANSI B1.1
<b>N</b>	NPT螺纹 American Standard Taper Pipe Threads	GB/T 12716, ANSI B1.20.1
<b>R</b>	BSPT圆锥外螺纹 British Standard Taper Pipe Threads, External	GB 7306, ISO 7/1, BS 21, JIS B0203
<b>Z</b>	ZM米制锥螺纹 Metric Taper Threads	GB/T 1415

**端口及密封型式 Ports and Sealing type**

参见附录A:油口和终端螺纹 See Appendix A: Ports and Stud Ends

## ③ 配管尺寸 Tube end size:

直通和弯通接头: 最大的管端外径尺寸; 单位: mm

三通和四通接头: 第一个管端外径尺寸; 单位: mm

**Straights & Elbows:** The largest tube end size, designated in millimeters

**Tees & Crosses:** The first tube end size, designated in millimeters

## ④ 系列 Series

系列 Series	管径 Tube OD	公称压力 PN(bar)	系列 Series	管径 Tube OD	公称压力 PN(bar)
L 轻型	6	315	S 重型	6	400
	8			8	
	10			10	
	12			12	
	15			14	
	18			16	
	22	160		20	
	28			25	
	35				
	42				

## ⑤ 其它端配管外径或终端螺纹尺寸

## Other ends tube o.d. or pipe thread size

其它端配管外径表示方法同③, 标注顺序如右图所示。

The designation of other tube end sizes are the same as ③, the order according to right fig.

终端螺纹尺寸按螺纹标准标注, 如M18×1.5, G1/2"等,

The designation of stud end sizes are according as standards, Such as: M18×1.5, G1/2" etc.

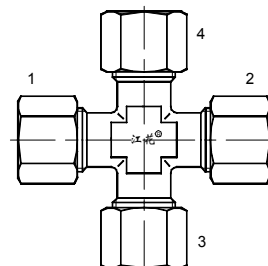

## ⑥ 材料代号:

## Material Code:

代号 Code	材料名称 Description	适用标准 Applicable standards	产品编号中代码 Code in Products No.
304	不锈钢 0Cr18Ni9 304 Stainless Steel	GB/T 1220	产品编号中"#"代码 1 Code 1 in Products No.
316	不锈钢 0Cr17Ni12Mo2 316 Stainless Steel	GB/T 1220	产品编号中"#"代码 2 Code 2 in Products No.
316L	不锈钢 00Cr17Ni12Mo2 316L Stainless Steel	GB/T 1220	产品编号中"#"代码 3 Code 3 in Products No.
C	优质碳素结构钢20# Carbon Steel	GB/T 699	产品编号中"#"代码 4 Code 4 in Products No.
BR	黄铜 H62 Brass	GB/T 4424	产品编号中"#"代码 5 Code 5 in Products No.

## 选型示例 Examples

单卡套端直通接头, 油口端螺纹G3/4", 密封型式B, 管径22, 系列L, 材质为316L不锈钢

表示为: **HYG2MCGB22L/G3/4" 316L**

Male Connector, Stud end size: G3/4", Seal type B, Tube OD: 22mm, L Series, Material: 316L stainless steel

Designation as: **HYG2MCGB22L/G3/4" 316L**

**G2U**  
直通中接头  
Union Straight

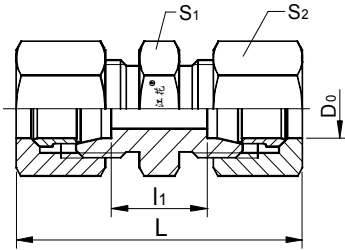

系列 Series	管子外径 Tube o.d.	PN	I1	L	S1	S2	产品编号 Product No	型号 Type
L	6	315	11	45	14	14	02001#01	G2U06L
	8	315	12	47	14	17	02001#02	G2U08L
	10	315	14	52	17	19	02001#03	G2U10L
	12	315	15	54	19	22	02001#04	G2U12L
	15	315	18	58	24	27	02001#05	G2U15L
	18	315	17	58	27	32	02001#06	G2U18L
	22	160	23	70	32	36	02001#07	G2U22L
	28	160	25	73	41	41	02001#08	G2U28L
	35	160	23	76	46	50	02001#09	G2U35L
	42	160	23	78	55	60	02001#10	G2U42L
S	6	400	16	51	14	17	02001#11	G2U06S
	8	400	18	55	17	19	02001#12	G2U08S
	10	400	19	59	19	22	02001#13	G2U10S
	12	400	21	61	22	24	02001#14	G2U12S
	14	400	22	65	24	27	02001#15	G2U14S
	16	400	21	65	27	30	02001#16	G2U16S
	20	400	23	75	32	36	02001#17	G2U20S
	25	400	26	82	41	46	02001#18	G2U25S
	30	400	27	91	46	50	02001#19	G2U30S

**G2BU**  
隔壁直通管接头  
Bulkhead Union Straight

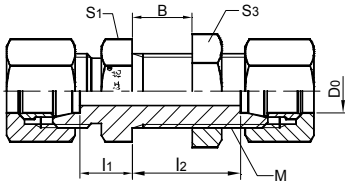

B最大值=16mm  
B Max=16mm

系列 Series	管子外径 Tube o.d.	PN	D0	I1	I3	M	S1	S3	产品编号 Product No	型号 Type
L	6	315	6	8	27	M12×1.5	17	17	02003#01	G2BU06L
	8	315	8	9	27	M14×1.5	19	19	02003#02	G2BU08L
	10	315	10	10	28	M16×1.5	22	22	02003#03	G2BU10L
	12	315	12	11	29	M18×1.5	24	24	02003#04	G2BU12L
	15	315	15	13	31	M22×1.5	27	30	02003#05	G2BU15L
	18	315	18	13.5	32.5	M26×1.5	32	36	02003#06	G2BU18L
	22	160	22	16.5	34.5	M30×2	36	41	02003#07	G2BU22L
	28	160	28	18.5	35.5	M36×2	41	46	02003#08	G2BU28L
	35	160	35	18.5	36.5	M45×2	50	55	02003#09	G2BU35L
	42	160	42	19	36	M52×2	60	65	02003#10	G2BU42L
S	6	400	6	12	29	M14×1.5	19	19	02003#11	G2BU06S
	8	400	8	13	29	M16×1.5	22	22	02003#12	G2BU08S
	10	400	10	14.5	29.5	M18×1.5	24	24	02003#13	G2BU10S
	12	400	12	14.5	30.5	M20×1.5	27	27	02003#14	G2BU12S
	14	400	14	17	32	M22×1.5	30	30	02003#15	G2BU14S
	16	400	16	16.5	31.5	M24×1.5	32	32	02003#16	G2BU16S
	20	400	20	17.5	33.5	M30×2	36	41	02003#17	G2BU20S
	25	400	25	20	35	M36×2	46	46	02003#18	G2BU25S
	30	400	30	21.5	37.5	M42×2	50	50	02003#19	G2BU32S

**G2UR**  
直通变径接头  
Union Reducer

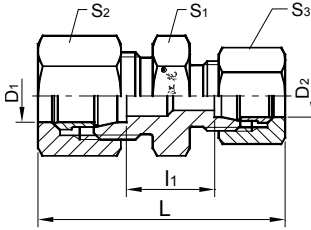

系列	PN	D1	D2	I1	L	S1	S2	S3	产品编号	型号
Series	PN	D1	D2	I1	L	S1	S2	S3	Product No	Type
L	315	8	6	12	46.5	14	17	14	02002#01	G2UR08/06L
	315	10	6	13	49	17	19	14	02002#02	G2UR10/06L
	315	10	8	13	49.5	17	19	17	02002#03	G2UR10/08L
	315	12	6	14	50.5	19	22	14	02002#04	G2UR12/06L
	315	12	8	14	51	19	22	17	02002#05	G2UR12/08L
	315	12	10	15	53.5	19	22	19	02002#06	G2UR12/10L
	315	15	8	16	53.5	24	27	17	02002#07	G2UR15/08L
	315	15	10	17	56	24	27	19	02002#08	G2UR15/10L
	315	15	12	17	56.5	24	27	22	02002#09	G2UR15/12L
	315	18	10	16.5	56	27	32	19	02002#10	G2UR18/10L
	315	18	12	16.5	56.5	27	32	22	02002#11	G2UR18/12L
	160	22	12	20.5	63.5	32	36	22	02002#12	G2UR22/12L
	160	22	15	21.5	65	32	36	27	02002#13	G2UR22/15L
	160	22	18	21	65	32	36	32	02002#14	G2UR22/18L
	160	28	18	23	67.5	41	41	32	02002#15	G2UR28/18L
	160	28	22	25	72.5	41	41	36	02002#16	G2UR28/22L
	160	35	22	24	74	46	50	41	02002#17	G2UR35/22L
	160	35	28	24	74.5	46	50	41	02002#18	G2UR35/28L
	160	42	35	23.5	77.5	55	60	50	02002#19	G2UR42/35L
S	400	8	6	18	54	17	19	17	02002#20	G2UR08/06S
	400	10	6	17.5	56	19	22	17	02002#21	G2UR10/06S
	400	10	8	17.5	57	19	22	19	02002#22	G2UR10/08S
	400	12	6	19.5	58	22	24	17	02002#23	G2UR12/06S
	400	12	8	19.5	59	22	24	19	02002#24	G2UR12/08S
	400	12	10	19	61	22	24	22	02002#25	G2UR12/10S
	400	14	10	20.5	63	24	27	22	02002#26	G2UR14/10S
	400	14	12	20.5	63	24	27	24	02002#27	G2UR14/12S
	400	16	12	20	63	27	30	24	02002#28	G2UR16/12S
	400	16	14	21.5	65	27	30	27	02002#29	G2UR16/14S
	400	20	10	22	69	32	36	22	02002#30	G2UR20/10S
	400	20	12	22	69	32	36	24	02002#31	G2UR20/12S
	400	20	16	23	71	32	36	30	02002#32	G2UR20/16S
	400	25	16	25.5	75.5	41	46	30	02002#33	G2UR25/16S
	400	25	20	25.5	79.5	41	46	36	02002#34	G2UR25/20S
	400	30	20	26	84	46	50	36	02002#35	G2UR30/20S
	400	30	25	26.5	86.5	46	50	41	02002#36	G2UR30/25S

## G2MCMA

端直通接头—公制螺纹垫片密封 (型式A)

Male Connector—Metric Thread End with Gasket Seal Type A

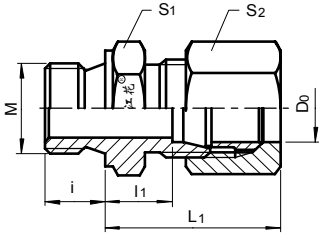

系列	PN	D0	M	i	l1	L1	S1	S2	产品编号	型号
Series	PN	D0	M	i	l1	L1	S1	S2	Product No	Type
L	315	6	M10×1	8	8.5	25.5	14	14	02004#01	G2MCMA06L
	315	8	M12×1.5	12	10	27.5	17	17	02004#02	G2MCMA08L
	315	8	M18×1.5	12	11.5	29	24	17	02004#03	G2MCMA08L/M18×1.5
	315	10	M14×1.5	12	11	30	19	19	02004#04	G2MCMA10L
	315	10	M16×1.5	12	12	31	22	19	02004#05	G2MCMA10L/M16×1.5
	315	10	M18×1.5	12	12.5	31.5	24	19	02004#06	G2MCMA10L/M18×1.5
	315	10	M22×1.5	14	14	33	27	19	02004#07	G2MCMA10L/M22×1.5
	315	12	M14×1.5	12	11	30.5	19	22	02004#08	G2MCMA12L/M14×1.5
	315	12	M16×1.5	12	12.5	32	22	22	02004#09	G2MCMA12L
	315	12	M18×1.5	12	12.5	32	24	22	02004#10	G2MCMA12L/M18×1.5
	315	12	M22×1.5	14	14	33.5	27	22	02004#11	G2MCMA12L/M22×1.5
	250	15	M16×1.5	12	13	33	24	27	02004#12	G2MCMA15L/M16×1.5
	250	15	M18×1.5	12	13.5	33.5	24	27	02004#13	G2MCMA15L
	250	15	M22×1.5	14	15	35	27	27	02004#14	G2MCMA15L/M22×1.5
	250	18	M18×1.5	12	14	34.5	27	32	02004#15	G2MCMA18L/M18×1.5
	250	18	M22×1.5	14	14.5	35	27	32	02004#16	G2MCMA18L
	160	22	M27×2	16	16.5	40	32	36	02004#17	G2MCMA22L
	160	28	M33×2	18	18.5	42.5	41	41	02004#18	G2MCMA28L
	160	35	M42×2	20	18.5	45	50	50	02004#19	G2MCMA35L
	160	42	M48×2	22	19	46.5	55	60	02004#20	G2MCMA42L
S	400	6	M12×1.5	12	13	30.5	17	17	02004#21	G2MCMA06S
	400	6	M14×1.5	12	15	32.5	19	17	02004#22	G2MCMA06S/M14×1.5
	400	8	M14×1.5	12	15	33.5	19	19	02004#23	G2MCMA08S
	400	10	M16×1.5	12	15	35	22	22	02004#24	G2MCMA10S
	400	12	M14×1.5	12	16.5	36.5	22	24	02004#25	G2MCMA12S/M14×1.5
	400	12	M18×1.5	12	17	37	24	24	02004#26	G2MCMA12S
	400	12	M22×1.5	14	17.5	37.5	27	24	02004#27	G2MCMA12S/M22×1.5
	400	14	M18×1.5	14	18	39.5	27	27	02004#28	G2MCMA14S/M18×1.5
	400	14	M20×1.5	14	19	40.5	27	27	02004#29	G2MCMA14S
	400	16	M18×1.5	14	18	40	27	30	02004#30	G2MCMA16S/M18×1.5
	400	16	M22×1.5	14	18.5	40.5	27	30	02004#31	G2MCMA16S
	400	20	M27×2	16	20.5	46.5	32	36	02004#32	G2MCMA20S
	250	25	M33×2	18	23	51	41	46	02004#33	G2MCMA25S
	250	30	M42×2	20	26	58	50	50	02004#34	G2MCMA30S

注: 米制螺纹M终端 (型式A) 常规采用带弹性体的组合垫片密封, 金属平垫也可适用。

NOTE: Metric thread ends M (Form A) are typically used with a gasket having a bonded elastomer seal. The flat metal gaskets may also be used.



## G2LMCMA

端直通长管接头—公制螺纹垫片密封(型式A)

Long Male Connector—Metric Thread End with Gasket seal Type A

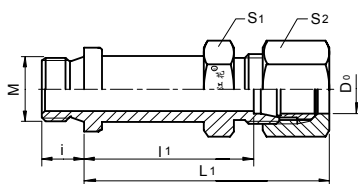

系列	PN	D0	M	i	l1	L1	S1	S2	产品编号	型号	
Series	PN	D0	M	i	l1	L1	S1	S2	Product No	Type	
L	315	6	M10×1	8	37	54	14	14	02005#01	G2MCMA06L	
	315	8	M12×1.5	12	44	61.5	17	17	02005#02	G2MCMA08L	
	315	8	M18×1.5	12	44	61.5	24	17	02005#03	G2MCMA08L/M18×1.5	
	315	10	M14×1.5	12	46	65	19	19	02005#04	G2MCMA10L	
	315	10	M16×1.5	12	46	65	22	19	02005#05	G2MCMA10L/M16×1.5	
	315	10	M18×1.5	12	46	65	24	19	02005#06	G2MCMA10L/M18×1.5	
	315	10	M22×1.5	14	46	65	27	19	02005#07	G2MCMA10L/M22×1.5	
	315	12	M14×1.5	12	48	67.5	19	22	02005#09	G2MCMA12L/M14×1.5	
	315	12	M16×1.5	12	48	67.5	22	22	02005#08	G2MCMA12L	
	315	12	M18×1.5	12	48	67.5	24	22	02005#10	G2MCMA12L/M18×1.5	
	315	12	M22×1.5	14	48	67.5	27	22	02005#11	G2MCMA12L/M22×1.5	
	250	15	M18×1.5	12	51	71	24	27	02005#14	G2MCMA15L	
	250	15	M22×1.5	14	51	71	27	27	02005#15	G2MCMA15L/M22×1.5	
	250	18	M22×1.5	14	52	72.5	27	30	02005#17	G2MCMA18L	
	160	22	M27×2	16	61.5	85	32	36	02005#19	G2MCMA22L	
	160	28	M33×2	18	67.5	91.5	41	41	02005#21	G2MCMA28L	
	160	35	M42×2	20	73.5	100	50	50	02005#24	G2MCMA35L	
	160	42	M48×2	22	74	101.5	55	60	02005#26	G2MCMA42L	
	S	400	6	M12×1.5	12	46.5	64	17	17	02005#27	G2MCMA06S
		400	6	M14×1.5	12	46.5	64	19	17	02005#28	G2MCMA06S/M14×1.5
		400	8	M14×1.5	12	49.5	68	19	19	02005#29	G2MCMA08S
		400	10	M16×1.5	12	51	71	22	22	02005#30	G2MCMA10S
		400	12	M14×1.5	12	53	73	22	24	02005#32	G2MCMA12S/M14×1.5
		400	12	M18×1.5	12	53	73	24	24	02005#31	G2MCMA12S
		400	12	M22×1.5	14	53	73	27	24	02005#33	G2MCMA12S/M22×1.5
		400	14	M18×1.5	14	55	76.5	27	27	02005#35	G2MCMA14S/M18×1.5
400		14	M20×1.5	14	55	76.5	27	27	02005#34	G2MCMA14S	
400		16	M18×1.5	14	57	78	27	30	02005#37	G2MCMA16S/M18×1.5	
400		16	M22×1.5	14	57	78	27	30	02005#36	G2MCMA16S	
400		20	M27×2	16	68	94	32	36	02005#39	G2MCMA20S	
250		25	M33×2	18	71.5	99.5	41	41	02005#41	G2MCMA25S	
250		30	M42×2	20	75	107	50	50	02005#43	G2MCMA30S	

注: 米制螺纹M终端(型式A) 常规采用带弹性体的组合垫片密封,金属平垫也可适用。

NOTE: Metric thread ends M (Form A) are typically used with a gasket having a bonded elastomer seal. The flat metal gaskets may also be used.

## G2MCGA

端直通接头—英制螺纹垫片密封 (型式A)

Male Connector—Whitworth BSPP(G) with Gasket Seal Type A

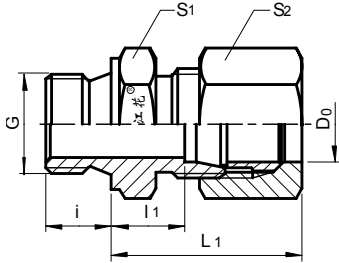

系列	PN	D0	G	i	l1	L1	S1	S2	产品编号	型号
Series	PN	D0	G	i	l1	L1	S1	S2	Product No	Type
L	315	6	G1/8A	8	8.5	25.5	14	14	02006#01	G2MCGA06L
	315	6	G1/4A	12	10	27	19	14	02006#02	G2MCGA06L/G1/4A
	315	6	G3/8A	12	11.5	28.5	22	14	02006#03	G2MCGA06L/G3/8A
	315	6	G1/2A	14	12	29	27	14	02006#04	G2MCGA06L/G1/2A
	315	8	G1/8A	8	9.5	27	14	17	02006#05	G2MCGA08L/G1/8A
	315	8	G1/4A	12	10	27.5	19	17	02006#06	G2MCGA08L
	315	8	G3/8A	12	11.5	29	22	17	02006#07	G2MCGA08L/G3/8A
	315	8	G1/2A	14	12	29.5	27	17	02006#08	G2MCGA08L/G1/2A
	315	10	G1/4A	12	11	30	19	19	02006#09	G2MCGA10L
	315	10	G3/8A	12	12.5	31.5	22	19	02006#10	G2MCGA10L/G3/8A
	315	10	G1/2A	14	13	32	27	19	02006#11	G2MCGA10L/G1/2A
	315	12	G1/4A	12	12	31.5	19	22	02006#12	G2MCGA12L/G1/4A
	315	12	G3/8A	12	12.5	32	22	22	02006#13	G2MCGA12L
	315	12	G1/2A	14	13	32.5	27	22	02006#14	G2MCGA12L/G1/2A
	315	12	G3/4A	16	14	33.5	32	22	02006#15	G2MCGA12L/G3/4A
	250	15	G3/8A	12	13.5	33.5	24	27	02006#16	G2MCGA15L/G3/8A
	250	15	G1/2A	14	14	34	27	27	02006#17	G2MCGA15L
	250	15	G3/4A	16	15	35	32	27	02006#18	G2MCGA15L/G3/4A
	250	18	G3/8A	12	14	34.5	27	32	02006#19	G2MCGA18L/G3/8A
	250	18	G1/2A	14	14.5	35	27	32	02006#20	G2MCGA18L
	250	18	G3/4A	16	14.5	35	32	32	02006#21	G2MCGA18L/G3/4A
	160	22	G1/2A	14	16.5	40	32	36	02006#22	G2MCGA22L/G1/2A
	160	22	G3/4A	16	16.5	40	32	36	02006#23	G2MCGA22L
	160	28	G3/4A	16	18.5	42.5	41	41	02006#24	G2MCGA28L/G3/4A
	160	28	G1A	18	18.5	42.5	41	41	02006#25	G2MCGA28L
	160	28	G11/4A	20	18.5	42.5	50	41	02006#26	G2MCGA28L/G11/4A
	160	35	G1A	18	18.5	45	46	50	02006#27	G2MCGA35L/G1A
	160	35	G11/4A	20	18.5	45	50	50	02006#28	G2MCGA35L
	160	35	G11/2A	22	18.5	45	55	50	02006#29	G2MCGA35L/G11/2A
	160	42	G1A	18	19	46.5	55	60	02006#30	G2MCGA42L/G1A
	160	42	G11/4A	20	19	46.5	55	60	02006#31	G2MCGA42L/G11/4A
	160	42	G11/2A	22	19	46.5	55	60	02006#32	G2MCGA42L

注: BSPP圆柱管螺纹终端 (型式A) 常规采用带弹性体的组合垫片密封,金属平垫也可适用。

NOTE: BSPP parallel thread ends (Form A) are typically used with a gasket having a bonded elastomer seal. The flat metal gaskets may also be used.

## G2MCGA

端直通接头—英制螺纹垫片密封

Male Connector—Whitworth BSPP(G) with Gasket Seal Type A

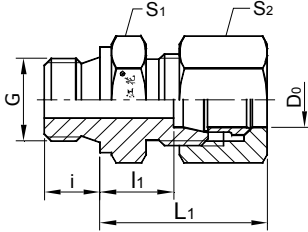

系列	PN	D0	G	i	l1	L1	S1	S2	产品编号	型号
Series	PN	D0	G	i	l1	L1	S1	S2	Product No	Type
S	400	6	G1/8A	8	12.5	30	14	17	02006#33	G2MCGA06S/G1/8A
	400	6	G1/4A	12	13	30.5	19	17	02006#34	G2MCGA06S
	400	6	G3/8A	12	15.5	33	22	17	02006#35	G2MCGA06S/G3/8A
	400	6	G1/2A	14	18	35.5	27	17	02006#36	G2MCGA06S/G1/2A
	400	8	G1/4A	12	15	33.5	19	19	02006#37	G2MCGA08S
	400	8	G3/8A	12	15.5	34	22	19	02006#38	G2MCGA08S/G3/8A
	400	8	G1/2A	14	18	36.5	27	19	02006#39	G2MCGA08S/G1/2A
	400	10	G1/4A	12	14.5	34.5	19	22	02006#40	G2MCGA10S/G1/4A
	400	10	G3/8A	12	15	35	22	22	02006#41	G2MCGA10S
	400	10	G1/2A	14	17.5	37.5	27	22	02006#42	G2MCGA10S/G1/2A
	400	12	G1/4A	12	16.5	36.5	22	24	02006#43	G2MCGA12S/G1/4A
	400	12	G3/8A	12	17	37	22	24	02006#44	G2MCGA12S
	400	12	G1/2A	14	17.5	37.5	27	24	02006#45	G2MCGA12S/G1/2A
	400	14	G3/8A	14	18.5	40	24	27	02006#46	G2MCGA14S/G3/8A
	400	14	G1/2A	14	19	40.5	27	27	02006#47	G2MCGA14S
	250	16	G3/8A	14	18	40	27	30	02006#48	G2MCGA16S/G3/8A
	250	16	G1/2A	14	18.5	40.5	27	30	02006#49	G2MCGA16S
	250	16	G3/4A	16	20.5	42.5	32	30	02006#50	G2MCGA16S/G3/4A
	250	20	G1/2A	14	20.5	46.5	32	36	02006#51	G2MCGA20S/G1/2A
	250	20	G3/4A	16	20.5	56.5	32	36	02006#52	G2MCGA20S
	250	20	G1A	18	22.5	48.5	41	36	02006#53	G2MCGA20S/G1A
	250	25	G3/4A	16	23	51	41	46	02006#54	G2MCGA25S/G3/4A
	250	25	G1A	18	23	51	41	46	02006#55	G2MCGA25S
	250	25	G11/4A	20	23	51	50	46	02006#56	G2MCGA25S/G11/4A
	160	30	G1A	18	23.5	55.5	46	50	02006#57	G2MCGA30S/G1A
	160	30	G11/4A	20	23.5	55.5	50	50	02006#58	G2MCGA30S

注: BSPP圆柱管螺纹终端(型式A)常规采用带弹性体的组合垫片密封,金属平垫也可适用。

NOTE: BSPP parallel thread ends (Form A) are typically used with a gasket having a bonded elastomer seal. The flat metal gaskets may also be used.

## G2MCMB

端直通接头—公制螺纹唇边密封 (型式B)

Male Connector—Metric Thread End with Cutting Face Seal Type B

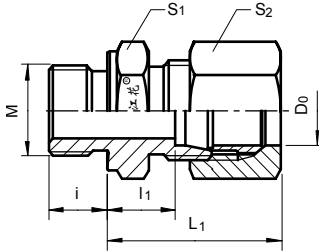

系列	PN	D0	M	i	l1	L1	S1	S2	产品编号	型号
Series	PN	D0	M	i	l1	L1	S1	S2	Product No	Type
L	315	6	M10×1	8	8.5	25.5	14	14	02007#01	G2MCMB06L
	315	8	M12×1.5	12	10	27.5	17	17	02007#02	G2MCMB08L
	315	8	M18×1.5	12	11.5	29	24	17	02007#03	G2MCMB08L/M18×1.5
	315	10	M14×1.5	12	11	30	19	19	02007#04	G2MCMB10L
	315	10	M16×1.5	12	12	31	22	19	02007#05	G2MCMB10L/M16×1.5
	315	10	M18×1.5	12	12.5	31.5	24	19	02007#06	G2MCMB10L/M18×1.5
	315	10	M22×1.5	14	14	33	27	19	02007#07	G2MCMB10L/M22×1.5
	315	12	M14×1.5	12	11	30.5	19	22	02007#08	G2MCMB12L/M14×1.5
	315	12	M16×1.5	12	12.5	32	22	22	02007#09	G2MCMB12L
	315	12	M18×1.5	12	12.5	32	24	22	02007#10	G2MCMB12L/M18×1.5
	315	12	M22×1.5	14	14	33.5	27	22	02007#11	G2MCMB12L/M22×1.5
	250	15	M16×1.5	12	13	33	24	27	02007#12	G2MCMB15L/M16×1.5
	250	15	M18×1.5	12	13.5	33.5	24	27	02007#13	G2MCMB15L
	250	15	M22×1.5	14	15	35	27	27	02007#14	G2MCMB15L/M22×1.5
	250	18	M18×1.5	12	14	34.5	27	32	02007#15	G2MCMB18L/M18×1.5
	250	18	M22×1.5	14	14.5	35	27	32	02007#16	G2MCMB18L
	160	22	M27×2	16	16.5	40	32	36	02007#17	G2MCMB22L
	160	28	M33×2	18	18.5	42.5	41	41	02007#18	G2MCMB28L
	160	35	M42×2	20	18.5	45	50	50	02007#19	G2MCMB35L
	160	42	M48×2	22	19	46.5	55	60	02007#20	G2MCMB42L
S	400	6	M12×1.5	12	13	30.5	17	17	02007#21	G2MCMB06S
	400	6	M14×1.5	12	15	32.5	19	17	02007#22	G2MCMB06S/M14×1.5
	400	8	M14×1.5	12	15	33.5	19	19	02007#23	G2MCMB08S
	400	10	M16×1.5	12	15	35	22	22	02007#24	G2MCMB10S
	400	12	M14×1.5	12	16.5	36.5	22	24	02007#25	G2MCMB12S/M14×1.5
	400	12	M18×1.5	12	17	37	24	24	02007#26	G2MCMB12S
	400	12	M22×1.5	14	17.5	37.5	27	24	02007#27	G2MCMB12S/M22×1.5
	400	14	M18×1.5	12	18	39.5	24	27	02007#28	G2MCMB14S/M18×1.5
	400	14	M20×1.5	14	19	40.5	27	27	02007#29	G2MCMB14S
	400	16	M18×1.5	14	18	40	27	30	02007#30	G2MCMB16S/M18×1.5
	400	16	M22×1.5	14	18.5	40.5	27	30	02007#31	G2MCMB16S
	400	20	M27×2	16	20.5	46.5	32	36	02007#32	G2MCMB20S
	250	25	M33×2	18	23	51	41	41	02007#33	G2MCMB25S
	160	30	M42×2	20	26	58	50	50	02007#34	G2MCMB30S

注: 米制螺纹M终端 (型式B) 常规唇边密封, 金属平垫也可适用。

NOTE: Metric thread ends M (Form B) are typically sealed with cutting face. The flat metal gaskets may also be used.

## G2MCGB

## 端直通接头—英制螺纹唇边密封

Male Connector—Whitworth BSPP(G) with cutting face seal

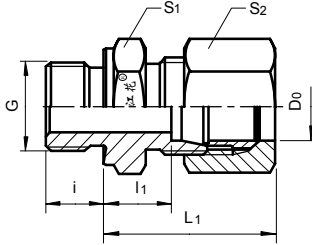

系列	PN	D0	G	i	l1	L1	S1	S2	产品编号	型号
Series	PN	D0	G	i	l1	L1	S1	S2	Product No	Type
L	315	6	G1/8A	8	8.5	25.5	14	14	02008#01	G2MCGB06L
	315	6	G1/4A	12	10	27	19	14	02008#02	G2MCGB06L/G1/4A
	315	6	G3/8A	12	11.5	28.5	22	14	02008#03	G2MCGB06L/G3/8A
	315	6	G1/2A	14	12	29	27	14	02008#04	G2MCGB06L/G1/2A
	315	8	G1/8A	8	9.5	27	14	17	02008#05	G2MCGB08L/G1/8A
	315	8	G1/4A	12	10	27.5	19	17	02008#06	G2MCGB08L
	315	8	G3/8A	12	11.5	29	22	17	02008#07	G2MCGB08L/G3/8A
	315	8	G1/2A	14	12	29.5	27	17	02008#08	G2MCGB08L/G1/2A
	315	10	G1/4A	12	11	30	19	19	02008#09	G2MCGB10L
	315	10	G3/8A	12	12.5	31.5	22	19	02008#10	G2MCGB10L/G3/8A
	315	10	G1/2A	14	13	32	27	19	02008#11	G2MCGB10L/G1/2A
	315	12	G1/4A	12	12	31.5	19	22	02008#12	G2MCGB12L/G1/4A
	315	12	G3/8A	12	12.5	32	22	22	02008#13	G2MCGB12L
	315	12	G1/2A	14	13	32.5	27	22	02008#14	G2MCGB12L/G1/2A
	315	12	G3/4A	16	14	33.5	32	22	02008#15	G2MCGB12L/G3/4A
	250	15	G3/8A	12	13.5	33.5	24	27	02008#16	G2MCGB15L/G3/8A
	250	15	G1/2A	14	14	34	27	27	02008#17	G2MCGB15L
	250	15	G3/4A	16	15	35	32	27	02008#18	G2MCGB15L/G3/4A
	250	18	G3/8A	12	14	34.5	27	32	02008#19	G2MCGB18L/G3/8A
	250	18	G1/2A	14	14.5	35	27	32	02008#20	G2MCGB18L
	250	18	G3/4A	16	14.5	35	32	32	02008#21	G2MCGB18L/G3/4A
	160	22	G1/2A	14	16.5	40	32	36	02008#22	G2MCGB22L/G1/2A
	160	22	G3/4A	16	16.5	40	32	36	02008#23	G2MCGB22L
	160	28	G3/4A	16	18.5	42.5	41	41	02008#24	G2MCGB28L/G3/4A
	160	28	G1A	18	18.5	42.5	41	41	02008#25	G2MCGB28L
	160	28	G11/4A	20	18.5	42.5	50	41	02008#26	G2MCGB28L/G11/4A
	160	35	G1A	18	18.5	45	46	50	02008#27	G2MCGB35L/G1A
	160	35	G11/4A	20	18.5	45	50	50	02008#28	G2MCGB35L
	160	35	G11/2A	22	18.5	45	55	50	02008#29	G2MCGB35L/G11/2A
	160	42	G1A	18	19	46.5	55	60	02008#30	G2MCGB42L/G1A
	160	42	G11/4A	20	19	46.5	55	60	02008#31	G2MCGB42L/G11/4A
	160	42	G11/2A	22	19	46.5	55	60	02008#32	G2MCGB42L

注: BSPP螺纹终端(型式B)常规唇边密封,金属平垫也可适用。

NOTE: BSPP(G) thread ends (Form B) are typically sealed with cutting face. The flat metal gaskets may also be used.

## G2MCGB

端直连接头—英制螺纹唇边密封(型式B)

Male Connector—Whitworth BSPP(G) with Cutting Face Seal Type B

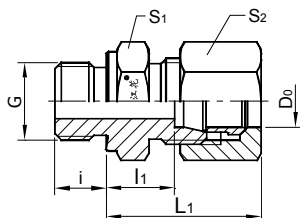

系列	PN	D0	G	i	l1	L1	S1	S2	产品编号	型号
Series	PN	D0	G	i	l1	L1	S1	S2	Product No	Type
S	400	6	G1/8A	8	12.5	30	14	17	02008#33	G2MCGB06S/G1/8A
	400	6	G1/4A	12	13	30.5	19	17	02008#34	G2MCGB06S
	400	6	G3/8A	12	15.5	33	22	17	02008#35	G2MCGB06S/G3/8A
	400	6	G1/2A	14	18	35.5	27	17	02008#36	G2MCGB06S/G1/2A
	400	8	G1/4A	12	15	33.5	19	19	02008#37	G2MCGB08S
	400	8	G3/8A	12	15.5	34	22	19	02008#38	G2MCGB08S/G3/8A
	400	8	G1/2A	14	18	36.5	27	19	02008#39	G2MCGB08S/G1/2A
	400	10	G1/4A	12	14.5	34.5	19	22	02008#40	G2MCGB10S/G1/4A
	400	10	G3/8A	12	15	35	22	22	02008#41	G2MCGB10S
	400	10	G1/2A	14	17.5	37.5	27	22	02008#42	G2MCGB10S/G1/2A
	400	12	G1/4A	12	16.5	36.5	22	24	02008#43	G2MCGB12S/G1/4A
	400	12	G3/8A	12	17	37	22	24	02008#44	G2MCGB12S
	400	12	G1/2A	14	17.5	37.5	27	24	02008#45	G2MCGB12S/G1/2A
	400	14	G3/8A	14	18.5	40	24	27	02008#46	G2MCGB14S/G3/8A
	400	14	G1/2A	14	19	40.5	27	27	02008#47	G2MCGB14S
	250	16	G3/8A	14	18	40	27	30	02008#48	G2MCGB16S/G3/8A
	250	16	G1/2A	14	18.5	40.5	27	30	02008#49	G2MCGB16S
	250	16	G3/4A	16	20.5	42.5	32	30	02008#50	G2MCGB16S/G3/4A
	250	20	G1/2A	14	20.5	46.5	32	36	02008#51	G2MCGB20S/G1/2A
	250	20	G3/4A	16	20.5	56.5	32	36	02008#52	G2MCGB20S
	250	20	G1A	18	22.5	48.5	41	36	02008#53	G2MCGB20S/G1A
	250	25	G3/4A	16	23	51	41	46	02008#54	G2MCGB25S/G3/4A
	250	25	G1A	18	23	51	41	46	02008#55	G2MCGB25S
	250	25	G11/4A	20	23	51	50	46	02008#56	G2MCGB25S/G11/4A
	160	30	G1A	18	23.5	55.5	46	50	02008#57	G2MCGB30S/G1A
	160	30	G11/4A	20	23.5	55.5	50	50	02008#58	G2MCGB30S

注: BSPP螺纹终端(型式B)常规唇边密封,金属平垫也可适用。

NOTE: BSPP(G) thread ends (Form B) are typically sealed with cutting face. The flat metal gaskets may also be used.

## G2MCME

端直通接头—公制螺纹U型圈密封 (型式E)

Male Connector—Metric Thread with U-ring Seal Type E

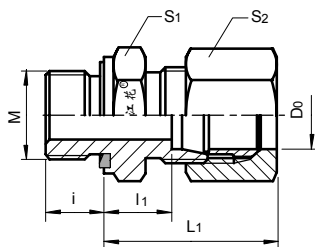

系列	PN	D0	M	i	l1	L1	S1	S2	产品编号	型号
Series	PN	D0	M	i	l1	L1	S1	S2	Product No	Type
L	315	6	M10×1	8	8.5	25.5	14	14	02009#01	G2MCME06L
	315	8	M12×1.5	12	10	27.5	17	17	02009#02	G2MCME08L
	315	8	M18×1.5	12	11.5	29	24	17	02009#03	G2MCME08L/M18×1.5
	315	10	M14×1.5	12	11	30	19	19	02009#04	G2MCME10L
	315	10	M16×1.5	12	12	31	22	19	02009#05	G2MCME10L/M16×1.5
	315	10	M18×1.5	12	12.5	31.5	24	19	02009#06	G2MCME10L/M18×1.5
	315	10	M22×1.5	14	14	33	27	19	02009#07	G2MCME10L/M22×1.5
	315	12	M14×1.5	12	11	30.5	19	22	02009#08	G2MCME12L/M14×1.5
	315	12	M16×1.5	12	12.5	32	22	22	02009#09	G2MCME12L
	315	12	M18×1.5	12	12.5	32	24	22	02009#10	G2MCME12L/M18×1.5
	315	12	M22×1.5	14	14	33.5	27	22	02009#11	G2MCME12L/M22×1.5
	250	15	M18×1.5	12	13.5	33.5	24	27	02009#12	G2MCME15L
	250	15	M22×1.5	14	15	35	27	27	02009#13	G2MCME15L/M22×1.5
	250	18	M22×1.5	14	14.5	35	27	32	02009#14	G2MCME18L
	160	22	M27×2	16	16.5	40	32	36	02009#15	G2MCME22L
	160	28	M33×2	18	18.5	42.5	41	41	02009#16	G2MCME28L
	160	35	M42×2	20	18.5	45	50	50	02009#17	G2MCME35L
	160	42	M48×2	22	19	46.5	55	60	02009#18	G2MCME42L
S	400	6	M12×1.5	12	13	30.5	17	17	02009#19	G2MCME06S
	400	6	M14×1.5	12	15	32.5	19	17	02009#20	G2MCME06S/M14×1.5
	400	8	M14×1.5	12	15	33.5	19	19	02009#21	G2MCME08S
	400	10	M16×1.5	12	15	35	22	22	02009#22	G2MCME10S
	400	12	M14×1.5	12	16.5	36.5	22	24	02009#23	G2MCME12S/M14×1.5
	400	12	M18×1.5	12	17	37	24	24	02009#24	G2MCME12S
	400	12	M22×1.5	14	17.5	37.5	27	24	02009#25	G2MCME12S/M22×1.5
	400	14	M18×1.5	14	18	39.5	27	27	02009#26	G2MCME14S/M18×1.5
	400	14	M20×1.5	14	19	40.5	27	27	02009#27	G2MCME14S
	400	16	M18×1.5	14	18	40	27	30	02009#28	G2MCME16S/M18×1.5
	400	16	M22×1.5	14	18.5	40.5	27	30	02009#29	G2MCME16S
	400	20	M27×2	16	20.5	46.5	32	36	02009#30	G2MCME20S
	250	25	M33×2	18	23	51	41	46	02009#31	G2MCME25S
	160	30	M42×2	20	26	58	50	50	02009#32	G2MCME30S

## G2MCGE

端直通接头—英制螺纹U型圈密封(型式E)

Male Connector—Whitworth BSPP(G) with U-ring Seal Type E

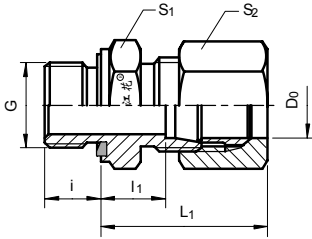

系列	PN	D0	G	i	l1	L1	S1	S2	产品编号	型号
Series	PN	D0	G	i	l1	L1	S1	S2	Product No	Type
L	315	6	G1/8A	8	8.5	25.5	14	14	02010#01	G2MCGE06L
	315	6	G1/4A	12	10	27	19	14	02010#02	G2MCGE06L/G1/4A
	315	6	G3/8A	12	11.5	28.5	22	14	02010#03	G2MCGE06L/G3/8A
	315	6	G1/2A	14	12	29	27	14	02010#04	G2MCGE06L/G1/2A
	315	8	G1/8A	8	9.5	27	14	17	02010#05	G2MCGE08L/G1/8A
	315	8	G1/4A	12	10	27.5	19	17	02010#06	G2MCGE08L
	315	8	G3/8A	12	11.5	29	22	17	02010#07	G2MCGE08L/G3/8A
	315	8	G1/2A	14	12	29.5	27	17	02010#08	G2MCGE08L/G1/2A
	315	10	G1/4A	12	11	30	19	19	02010#09	G2MCGE10L
	315	10	G3/8A	12	12.5	31.5	22	19	02010#10	G2MCGE10L/G3/8A
	315	10	G1/2A	14	13	32	27	19	02010#11	G2MCGE10L/G1/2A
	315	12	G1/4A	12	12	31.5	19	22	02010#12	G2MCGE12L/G1/4A
	315	12	G3/8A	12	12.5	32	22	22	02010#13	G2MCGE12L
	315	12	G1/2A	14	13	32.5	27	22	02010#14	G2MCGE12L/G1/2A
	315	12	G3/4A	16	14	33.5	32	22	02010#15	G2MCGE12L/G3/4A
	250	15	G3/8A	12	13.5	33.5	24	27	02010#16	G2MCGE15L/G3/8A
	250	15	G1/2A	14	14	34	27	27	02010#17	G2MCGE15L
	250	15	G3/4A	16	15	35	32	27	02010#18	G2MCGE15L/G3/4A
	250	18	G3/8A	12	14	34.5	27	32	02010#19	G2MCGE18L/G3/8A
	250	18	G1/2A	14	14.5	35	27	32	02010#20	G2MCGE18L
	250	18	G3/4A	16	14.5	35	32	32	02010#21	G2MCGE18L/G3/4A
	160	22	G1/2A	14	16.5	40	32	36	02010#22	G2MCGE22L/G1/2A
	160	22	G3/4A	16	16.5	40	32	36	02010#23	G2MCGE22L
	160	28	G3/4A	16	18.5	42.5	41	41	02010#24	G2MCGE28L/G3/4A
	160	28	G1A	18	18.5	42.5	41	41	02010#25	G2MCGE28L
	160	28	G11/4A	20	18.5	42.5	50	41	02010#26	G2MCGE28L/G11/4A
	160	35	G1A	18	18.5	45	46	50	02010#27	G2MCGE35L/G1A
	160	35	G11/4A	20	18.5	45	50	50	02010#28	G2MCGE35L
	160	35	G11/2A	22	18.5	45	55	50	02010#29	G2MCGE35L/G11/2A
	160	42	G1A	18	19	46.5	55	60	02010#30	G2MCGE42L/G1A
	160	42	G11/4A	20	19	46.5	55	60	02010#31	G2MCGE42L/G11/4A
	160	42	G11/2A	22	19	46.5	55	60	02010#32	G2MCGE42L



## G2MCGE

端直通接头—英制螺纹U型圈密封 (型式E)

Male Connector—Whitworth BSPP(G) with U-ring Seal Type E

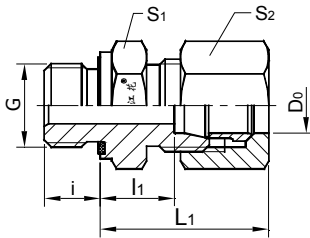

系列	PN	D0	G	i	l1	L1	S1	S2	产品编号	型号
Series	PN	D0	G	i	l1	L1	S1	S2	Product No	Type
S	400	6	G1/8A	8	12.5	30	14	17	02010#33	G2MCGE06S/G1/8A
	400	6	G1/4A	12	13	30.5	19	17	02010#34	G2MCGE06S
	400	6	G3/8A	12	15.5	33	22	17	02010#35	G2MCGE06S/G3/8A
	400	6	G1/2A	14	18	35.5	27	17	02010#36	G2MCGE06S/G1/2A
	400	8	G1/4A	12	15	33.5	19	19	02010#37	G2MCGE08S
	400	8	G3/8A	12	15.5	34	22	19	02010#38	G2MCGE08S/G3/8A
	400	8	G1/2A	14	18	36.5	27	19	02010#39	G2MCGE08S/G1/2A
	400	10	G1/4A	12	14.5	34.5	19	22	02010#40	G2MCGE10S/G1/4A
	400	10	G3/8A	12	15	35	22	22	02010#41	G2MCGE10S
	400	10	G1/2A	14	17.5	37.5	27	22	02010#42	G2MCGE10S/G1/2A
	400	12	G1/4A	12	16.5	36.5	22	24	02010#43	G2MCGE12S/G1/4A
	400	12	G3/8A	12	17	37	22	24	02010#44	G2MCGE12S
	400	12	G1/2A	14	17.5	37.5	27	24	02010#45	G2MCGE12S/G1/2A
	400	14	G3/8A	14	18.5	40	24	27	02010#46	G2MCGE14S/G3/8A
	400	14	G1/2A	14	19	40.5	27	27	02010#47	G2MCGE14S
	250	16	G3/8A	14	18	40	27	30	02010#48	G2MCGE16S/G3/8A
	250	16	G1/2A	14	18.5	40.5	27	30	02010#49	G2MCGE16S
	250	16	G3/4A	16	20.5	42.5	32	30	02010#50	G2MCGE16S/G3/4A
	250	20	G1/2A	14	20.5	46.5	32	36	02010#51	G2MCGE20S/G1/2A
	250	20	G3/4A	16	20.5	56.5	32	36	02010#52	G2MCGE20S
	250	20	G1A	18	22.5	48.5	41	36	02010#53	G2MCGE20S/G1A
	250	25	G3/4A	16	23	51	41	46	02010#54	G2MCGE25S/G3/4A
	250	25	G1A	18	23	51	41	46	02010#55	G2MCGE25S
	250	25	G11/4A	20	23	51	50	46	02010#56	G2MCGE25S/G11/4A
	160	30	G1A	18	23.5	55.5	46	50	02010#57	G2MCGE30S/G1A
	160	30	G11/4A	20	23.5	55.5	50	50	02010#58	G2MCGE30S

## G2MCMF

端直通接头—公制螺纹O型圈密封(ISO6149 型式F)

Male Connector—Metric Thread with O-ring Seal Type F (ISO6149-1 Ports)

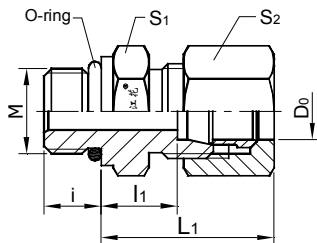

系列	PN	D0	M	i	l1	L1	S1	S2	产品编号	型号
Series	PN	D0	M	i	l1	L1	S1	S2	Product No	Type
L	315	6	M10×1	8	8.5	25.5	14	14	02011#01	G2MCMF06L
	315	8	M12×1.5	12	10	27.5	17	17	02011#02	G2MCMF08L
	315	8	M18×1.5	12	11.5	29	24	17	02011#03	G2MCMF08L/M18×1.5
	315	10	M14×1.5	12	11	30	19	19	02011#04	G2MCMF10L
	315	10	M16×1.5	12	12	31	22	19	02011#05	G2MCMF10L/M16×1.5
	315	10	M18×1.5	12	12.5	31.5	24	19	02011#06	G2MCMF10L/M18×1.5
	315	10	M22×1.5	14	14	33	27	19	02011#07	G2MCMF10L/M22×1.5
	315	12	M14×1.5	12	11	30.5	19	22	02011#08	G2MCMF12L/M14×1.5
	315	12	M16×1.5	12	12.5	32	22	22	02011#09	G2MCMF12L
	315	12	M18×1.5	12	12.5	32	24	22	02011#10	G2MCMF12L/M18×1.5
	315	12	M22×1.5	14	14	33.5	27	22	02011#11	G2MCMF12L/M22×1.5
	250	15	M18×1.5	12	13.5	33.5	24	27	02011#12	G2MCMF15L
	250	15	M22×1.5	14	15	35	27	27	02011#13	G2MCMF15L/M22×1.5
	250	18	M22×1.5	14	14.5	35	27	32	02011#14	G2MCMF18L
	160	22	M27×2	16	16.5	40	32	36	02011#15	G2MCMF22L
	160	28	M33×2	18	18.5	42.5	41	41	02011#16	G2MCMF28L
	160	35	M42×2	20	18.5	45	50	50	02011#17	G2MCMF35L
	160	42	M48×2	22	19	46.5	55	60	02011#18	G2MCMF42L
S	400	6	M12×1.5	12	13	30.5	17	17	02011#19	G2MCMF06S
	400	6	M14×1.5	12	15	32.5	19	17	02011#20	G2MCMF06S/M14×1.5
	400	8	M14×1.5	12	15	33.5	19	19	02011#21	G2MCMF08S
	400	10	M16×1.5	12	15	35	22	22	02011#22	G2MCMF10S
	400	12	M14×1.5	12	16.5	36.5	22	24	02011#23	G2MCMF12S/M14×1.5
	400	12	M18×1.5	12	17	37	24	24	02011#24	G2MCMF12S
	400	12	M22×1.5	14	17.5	37.5	27	24	02011#25	G2MCMF12S/M22×1.5
	400	14	M18×1.5	14	18	39.5	27	27	02011#26	G2MCMF14S/M18×1.5
	400	14	M20×1.5	14	19	40.5	27	27	02011#27	G2MCMF14S
	400	16	M18×1.5	14	18	40	27	30	02011#28	G2MCMF16S/M18×1.5
	400	16	M22×1.5	14	18.5	40.5	27	30	02011#29	G2MCMF16S
	400	20	M27×2	16	20.5	46.5	32	36	02011#30	G2MCMF20S
	250	25	M33×2	18	23	51	41	46	02011#31	G2MCMF25S
	160	30	M42×2	20	26	58	50	50	02011#32	G2MCMF30S

## G2MCUF

端直通接头—UN/UNF螺纹O型圈密封 (ISO 11926-1 型式F)

Male Connector—UN/UNF Thread with O-ring Seal Type F (ISO 11926-1 Ports)

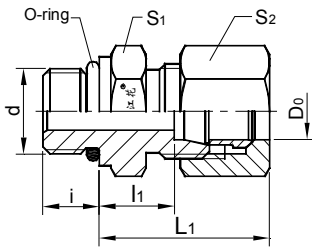

系列	PN	D0	d	i	l1	L1	S1	S2	产品编号	型号
Series	PN	D0	d	i	l1	L1	S1	S2	Product No	Type
L	315	8	7/16-20UNF	9	10	27.5	17	17	02012#01	G2GEUF08L/7/16UNF
	315	10	7/16-20UNF	10	11	30	17	19	02012#02	G2GEUF10L/7/16UNF
	315	12	9/16-18UNF	10	11	30.5	19	22	02012#03	G2GEUF12L/9/16UNF
	315	12	3/4-16UNF	11	13	32.5	24	22	02012#04	G2GEUF12L/3/4UNF
	315	12	7/8-14UNF	13	14	33.5	27	22	02012#05	G2GEUF12L/7/8UNF
	315	15	3/4-16UNF	11	14	34	24	27	02012#06	G2GEUF15L/3/4UNF
	315	15	7/8-14UNF	13	15	35	27	27	02012#07	G2GEUF15L/7/8UNF
	315	18	3/4-16UNF	11	14.5	35	27	32	02012#08	G2GEUF18L/3/4UNF
	315	18	7/8-14UNF	13	15	35.5	27	32	02012#09	G2GEUF18L/7/8UNF
	160	22	7/8-14UNF	13	16.5	40	32	36	02012#10	G2GEUF22L/7/8UNF
	160	22	1 1/16-12UN	15	16.5	40	32	36	02012#11	G2GEUF22L/1 1/16UN
	160	22	1 5/16-12UN	15	17.5	41	41	36	02012#12	G2GEUF22L/1 5/16UN
	160	28	1 1/16-12UN	15	18.5	42.5	41	41	02012#13	G2GEUF28L/1 1/16UN
	160	28	1 5/16-12UN	15	18.5	42.5	41	41	02012#14	G2GEUF28L/1 5/16UN
	160	35	1 5/16-12UN	15	18.5	45	46	50	02012#15	G2GEUF35L/1 5/16UN
	160	35	1 5/8-12UN	15	18.5	45	50	50	02012#16	G2GEUF35L/1 5/8UN
	160	42	1 5/8-12UN	15	19	46.5	55	60	02012#17	G2GEUF42L/1 5/8UN
S	400	8	7/16-20UNF	11	15	33.5	17	19	02012#18	G2GEUF08S/7/16UNF
	400	10	9/16-18UNF	12	15	35	19	22	02012#19	G2GEUF10S/9/16UNF
	400	12	9/16-18UNF	12	17	37	22	24	02012#20	G2GEUF12S/9/16UNF
	400	12	3/4-16UNF	14	17.5	37.5	24	24	02012#21	G2GEUF12S/3/4UNF
	400	16	3/4-16UNF	14	18.5	40.5	24	30	02012#22	G2GEUF16S/3/4UNF
	400	16	7/8-14UNF	16	18.5	40.5	27	30	02012#23	G2GEUF16S/7/8UNF
	400	20	3/4-16UNF	14	20.5	46.5	32	36	02012#24	G2GEUF20S/3/4UNF
	400	20	7/8-14UNF	16	20.5	46.5	32	36	02012#25	G2GEUF20S/7/8UNF
	400	20	1 1/16-12UN	18.5	20.5	46.5	32	36	02012#26	G2GEUF20S/1 1/16UN
	400	25	1 1/16-12UN	18.5	23	51	36	46	02012#27	G2GEUF25S/1 1/16UN
	400	25	1 5/16-12UN	18.5	23	51	41	46	02012#28	G2GEUF25S/1 5/16UN
	400	30	1 5/16-12UN	18.5	23.5	55.5	46	50	02012#29	G2GEUF30S/1 5/16UN
	400	30	1 5/8-12UN	18.5	23.5	55.5	50	50	02012#30	G2GEUF30S/1 5/8UN

## G2MCZ

端直通接头—米制锥管螺纹

Male Connector—Metrical ZM Taper thread

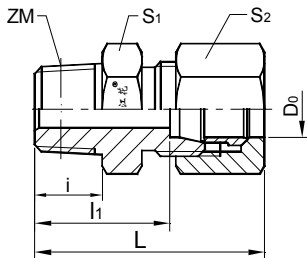

系列	PN	D0	ZM	i	l1	L1	S1	S2	产品编号	型号
Series	PN	D0	ZM	i	l1	L1	S1	S2	Product No	Type
L	315	6	ZM10	10	18	34	14	14	02013#01	G2MCZ06L/ZM10
	315	8	ZM14	16	25	40	17	17	02013#02	G2MCZ08L/ZM14
	315	10	ZM14	16	26	42	17	19	02013#03	G2MCZ10L/ZM14
	315	12	ZM18	16	27	43	22	22	02013#04	G2MCZ12L/ZM18
	315	15	ZM22	16	29	44	24	27	02013#05	G2MCZ15L/ZM22
	315	18	ZM22	16	28.5	45	27	32	02013#06	G2MCZ18L/ZM22

## G2MCR

端直通过头—英制锥管螺纹

Male Connector—Whitworth BSP Taper thread

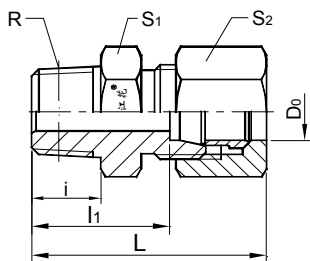

系列	PN	D0	R	i	l1	L1	S1	S2	产品编号	型号
Series	PN	D0	R	i	l1	L1	S1	S2	Product No	Type
L	250	6	R1/8	10	18	35	14	14	02014#01	G2MCR06L/R1/8
	250	6	R1/4	14.5	23	40	17	14	02014#02	G2MCR06L/R1/4
	250	6	R3/8	15	24	41	19	14	02014#03	G2MCR06L/R3/8
	250	6	R1/2	19	29	46	22	14	02014#04	G2MCR06L/R1/2
	250	8	R1/8	10	18	35.5	14	17	02014#05	G2MCR08L/R1/8
	250	8	R1/4	14.5	23	40.5	17	17	02014#06	G2MCR08L/R1/4
	250	8	R3/8	15	24	41.5	19	17	02014#07	G2MCR08L/R3/8
	250	8	R1/2	19	29	46.5	22	17	02014#08	G2MCR08L/R1/2
	250	10	R1/4	14.5	24	43	17	19	02014#09	G2MCR10L/R1/4
	250	10	R3/8	15	25	44	19	19	02014#10	G2MCR10L/R3/8
	250	10	R1/2	19	30	49	22	19	02014#11	G2MCR10L/R1/2
	250	12	R1/4	14.5	25	44.5	19	22	02014#12	G2MCR12L/R1/4
	250	12	R3/8	15	26	45.5	19	22	02014#13	G2MCR12L/R3/8
	250	12	R1/2	19	31	50.5	22	22	02014#14	G2MCR12L/R1/2
	250	15	R3/8	15	27	47	24	27	02014#15	G2MCR15L/R3/8
	250	15	R1/2	19	32	52	24	27	02014#16	G2MCR15L/R1/2
	250	15	R3/4	19	33	53	27	27	02014#17	G2MCR15L/R3/4
	250	18	R3/8	15	26.5	47	27	32	02014#18	G2MCR18L/R3/8
	250	18	R1/2	19	31.5	52	27	32	02014#19	G2MCR18L/R1/2
	250	18	R3/4	19	32.5	53	27	32	02014#20	G2MCR18L/R3/4
	160	22	R1/2	19	33.5	57	32	36	02014#21	G2MCR22L/R1/2
	160	22	R3/4	19	34.5	58	32	36	02014#22	G2MCR22L/R3/4
	160	28	R3/4	19	34.5	58.5	41	41	02014#23	G2MCR28L/R3/4
	160	28	R1	24	39.5	63.5	41	41	02014#24	G2MCR28L/R1
	160	28	R11/4	25	41.5	65.5	46	41	02014#25	G2MCR28L/R11/4
	160	35	R1	24	39.5	66	46	50	02014#26	G2MCR35L/R1
	160	35	R11/4	25	41	67.5	46	50	02014#27	G2MCR35L/R11/4
	160	35	R11/2	26	43	69.5	50	50	02014#28	G2MCR35L/R11/2
	160	42	R1	24	41	68.5	55	60	02014#29	G2MCR42L/R1
	160	42	R11/4	25	42	69.5	55	60	02014#30	G2MCR42L/R11/4
	160	42	R11/2	26	43	70.5	55	60	02014#31	G2MCR42L/R11/2

## G2MCN

端直连接头—NPT螺纹

Male Connector—NPT Thread

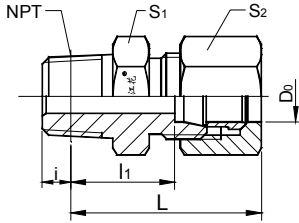

系列	PN	D0	NPT	i	l1	L1	S1	S2	产品编号	型号
Series	PN	D0	NPT	i	l1	L1	S1	S2	Product No	Type
L	250	6	1/8NPT	10	18	35	14	14	02015#01	G2MCN06L/1/8NPT
	250	6	1/4NPT	14.5	23	40	17	14	02015#02	G2MCN06L/1/4NPT
	250	6	3/8NPT	15	24	41	19	14	02015#03	G2MCN06L/3/8NPT
	250	6	1/2NPT	19	29	46	22	14	02015#04	G2MCN06L/1/2NPT
	250	8	1/8NPT	10	18	35.5	14	17	02015#05	G2MCN08L/1/8NPT
	250	8	1/4NPT	14.5	23	40.5	17	17	02015#06	G2MCN08L/1/4NPT
	250	8	3/8NPT	15	24	41.5	19	17	02015#07	G2MCN08L/3/8NPT
	250	8	1/2NPT	19	29	46.5	22	17	02015#08	G2MCN08L/1/2NPT
	250	10	1/4NPT	14.5	24	43	17	19	02015#09	G2MCN10L/1/4NPT
	250	10	3/8NPT	15	25	44	19	19	02015#10	G2MCN10L/3/8NPT
	250	10	1/2NPT	19	30	49	22	19	02015#11	G2MCN10L/1/2NPT
	250	12	1/4NPT	14.5	25	44.5	19	22	02015#12	G2MCN12L/1/4NPT
	250	12	3/8NPT	15	26	45.5	19	22	02015#13	G2MCN12L/3/8NPT
	250	12	1/2NPT	19	31	50.5	22	22	02015#14	G2MCN12L/1/2NPT
	250	15	3/8NPT	15	27	47	24	27	02015#15	G2MCN15L/3/8NPT
	250	15	1/2NPT	19	32	52	24	27	02015#16	G2MCN15L/1/2NPT
	250	15	3/4NPT	19	33	53	27	27	02015#17	G2MCN15L/3/4NPT
	250	18	3/8NPT	15	26.5	47	27	32	02015#18	G2MCN18L/3/8NPT
	250	18	1/2NPT	19	31.5	52	27	32	02015#19	G2MCN18L/1/2NPT
	250	18	3/4NPT	19	32.5	53	27	32	02015#20	G2MCN18L/3/4NPT
	160	22	1/2NPT	19	33.5	57	32	36	02015#21	G2MCN22L/1/2NPT
	160	22	3/4NPT	19	34.5	58	32	36	02015#22	G2MCN22L/3/4NPT
	160	28	3/4NPT	19	34.5	58.5	41	41	02015#24	G2MCN28L/3/4NPT
	160	28	1NPT	24	39.5	63.5	41	41	02015#23	G2MCN28L/1NPT
	160	28	1 1/4NPT	25	41.5	65.5	46	41	02015#25	G2MCN28L/1 1/4NPT
	160	35	1NPT	24	39.5	66	46	50	02015#26	G2MCN35L/1NPT
	160	35	1 1/4NPT	25	41	67.5	46	50	02015#27	G2MCN35L/1 1/4NPT
	160	35	1 1/2NPT	26	43	69.5	50	50	02015#28	G2MCN35L/1 1/2NPT
	160	42	1NPT	24	41	68.5	55	60	02015#29	G2MCN42L/1NPT
	160	42	1 1/4NPT	25	42	69.5	55	60	02015#30	G2MCN42L/1 1/4NPT
	160	42	1 1/2NPT	26	43	70.5	55	60	02015#31	G2MCN42L/1 1/2NPT

## G2MCN

端直连接头—NPT螺纹

Male Connector—NPT Thread

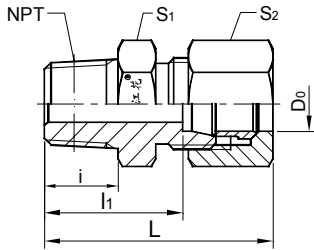

系列	PN	D0	NPT	i	l1	L1	S1	S2	产品编号	型号
Series	PN	D0	NPT	i	l1	L1	S1	S2	Product No	Type
S	400	6	1/8NPT	10	21	38.5	14	17	02015#32	G2MCN06S/1/8NPT
	400	6	1/4NPT	14.5	27	44.5	17	17	02015#33	G2MCN06S/1/4NPT
	400	6	3/8NPT	15	28	45.5	19	17	02015#34	G2MCN06S/3/8NPT
	400	6	1/2NPT	19	34	51.5	22	17	02015#35	G2MCN06S/1/2NPT
	400	8	1/4NPT	14.5	27	45.5	17	19	02015#36	G2MCN08S/1/4NPT
	400	8	3/8NPT	15	28	46.5	19	19	02015#37	G2MCN08S/3/8NPT
	400	8	1/2NPT	19	34	52.5	22	19	02015#38	G2MCN08S/1/2NPT
	400	10	1/4NPT	14.5	27.5	47.5	17	22	02015#39	G2MCN10S/1/4NPT
	400	10	3/8NPT	15	28	48	19	22	02015#40	G2MCN10S/3/8NPT
	400	10	1/2NPT	19	34.5	54.5	22	22	02015#41	G2MCN10S/1/2NPT
	400	10	3/4NPT	19	36.5	56.5	27	22	02015#42	G2MCN10S/3/4NPT
	400	12	1/4NPT	14.5	29	49	22	24	02015#43	G2MCN12S/1/4NPT
	400	12	3/8NPT	15	29.5	49.5	22	24	02015#44	G2MCN12S/3/8NPT
	400	12	1/2NPT	19	34.5	54.5	22	24	02015#45	G2MCN12S/1/2NPT
	400	12	3/4NPT	19	36.5	56.5	27	24	02015#46	G2MCN12S/3/4NPT
	400	14	3/8NPT	15	31	52.5	24	27	02015#47	G2MCN14S/3/8NPT
	400	14	1/2NPT	19	36	57.5	24	27	02015#48	G2MCN14S/1/2NPT
	400	14	3/4NPT	19	38	59.5	27	27	02015#49	G2MCN14S/3/4NPT
	400	16	3/8NPT	15	30.5	52.5	27	30	02015#50	G2MCN16S/3/8NPT
	400	16	1/2NPT	19	35.5	57.5	27	30	02015#51	G2MCN16S/1/2NPT
	400	16	3/4NPT	19	37.5	59.5	27	30	02015#52	G2MCN16S/3/4NPT
	400	16	1NPT	24	44.5	66.5	36	30	02015#53	G2MCN16S/1NPT
	400	20	1/2NPT	19	37.5	63.5	32	36	02015#54	G2MCN20S/1/2NPT
	400	20	3/4NPT	19	37.5	63.5	32	36	02015#55	G2MCN20/3/4NPT
	400	20	1NPT	24	44.5	70.5	36	36	02015#56	G2MCN20/1NPT
	400	25	3/4NPT	19	39	67	41	46	02015#57	G2MCN25S/3/4NPT
	400	25	1NPT	24	44	72	41	46	02015#58	G2MCN25S/1NPT
	400	25	11/4NPT	25	45	73	46	46	02015#59	G2MCN25S/11/4NPT
	400	25	11/2NPT	26	48	76	50	46	02015#60	G2MCN25S/11/2NPT
	400	30	3/4NPT	19	40.5	72.5	46	50	02015#61	G2MCN35S/3/4NPT
	400	30	1NPT	24	45.5	77.5	46	50	02015#62	G2MCN35S/1NPT
	400	30	11/4NPT	25	46.5	78.5	46	50	02015#63	G2MCN35S/11/4NPT
	400	30	11/2NPT	26	48.5	80.5	50	50	02015#64	G2MCN35S/11/2NPT

## G2LMCN

端直通长管接头—NPT螺纹

Long Male Connector—NPT Thread

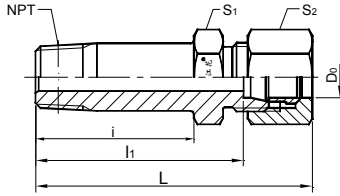

系列	PN	D0	NPT	i	l1	L1	S1	S2	产品编号	型号
Series	PN	D0	NPT	i	l1	L1	S1	S2	Product No	Type
L	250	6	1/8NPT	10	48	35	14	14	02016#01	G2MCN06L/1/8NPT
	250	6	1/4NPT	14.5	55	40	17	14	02016#02	G2MCN06L/1/4NPT
	250	8	1/8NPT	10	48	35.5	14	17	02016#03	G2MCN08L/1/8NPT
	250	8	1/4NPT	14.5	58	40.5	17	17	02016#04	G2MCN08L/1/4NPT
	250	8	3/8NPT	15	59	41.5	19	17	02016#05	G2MCN08L/3/8NPT
	250	10	1/4NPT	14.5	60	43	17	19	02016#06	G2MCN10L/1/4NPT
	250	10	3/8NPT	15	62	44	19	19	02016#07	G2MCN10L/3/8NPT
	250	10	1/2NPT	19	67	49	22	19	02016#08	G2MCN10L/1/2NPT
	250	12	1/4NPT	14.5	61.5	44.5	19	22	02016#09	G2MCN12L/1/4NPT
	250	12	3/8NPT	15	62.5	45.5	19	22	02016#10	G2MCN12L/3/8NPT
	250	12	1/2NPT	19	68.5	50.5	22	22	02016#11	G2MCN12L/1/2NPT
	250	15	1/2NPT	19	70.5	52	24	27	02016#12	G2MCN15L/1/2NPT
	250	15	3/4NPT	19	72.5	53	27	27	02016#13	G2MCN15L/3/4NPT
	250	18	1/2NPT	19	71	52	27	32	02016#14	G2MCN18L/1/2NPT
	250	18	3/4NPT	19	73	53	27	32	02016#15	G2MCN18L/3/4NPT
	160	22	1/2NPT	19	78.5	57	32	36	02016#16	G2MCN22L/1/2NPT
	160	22	3/4NPT	19	80.5	58	32	36	02016#17	G2MCN22/3/4NPT
	160	28	1NPT	24	91.5	63.5	41	41	02016#18	G2MCN28L/1NPT
	160	28	1 1/4NPT	25	95.5	65.5	46	41	02016#19	G2MCN28L/1 1/4NPT
	160	35	1 1/4NPT	25	96.5	67.5	46	50	02016#20	G2MCN35L/1 1/4NPT
	160	35	1 1/2NPT	26	98.5	69.5	50	50	02016#21	G2MCN35L/1 1/2NPT
	160	42	1 1/4NPT	25	98	69.5	55	60	02016#22	G2MCN42L/1 1/4NPT
	160	42	1 1/2NPT	26	99	70.5	55	60	02016#23	G2MCN42L/1 1/2NPT
S	400	6	1/8NPT	10	50	38.5	14	17	02016#24	G2MCN06S/1/8NPT
	400	6	1/4NPT	14.5	58	44.5	17	17	02016#25	G2MCN06S/1/4NPT
	400	8	1/4NPT	14.5	60	45.5	17	19	02016#26	G2MCN08S/1/4NPT
	400	8	3/8NPT	15	61	46.5	19	19	02016#27	G2MCN08S/3/8NPT
	400	10	3/8NPT	15	63.5	48	19	22	02016#29	G2MCN10S/3/8NPT
	400	10	1/2NPT	19	70	54.5	22	22	02016#30	G2MCN10S/1/2NPT
	400	12	3/8NPT	15	64.5	49.5	22	24	02016#31	G2MCN12S/3/8NPT
	400	12	1/2NPT	19	69.5	54.5	22	24	02016#32	G2MCN12S/1/2NPT
	400	14	1/2NPT	19	72	57.5	24	27	02016#33	G2MCN14S/1/2NPT
	400	14	3/4NPT	19	74	59.5	27	27	02016#34	G2MCN14S/3/4NPT
	400	16	1/2NPT	19	72	57.5	27	30	02016#35	G2MCN16S/1/2NPT
	400	16	3/4NPT	19	75	59.5	27	30	02016#36	G2MCN16S/3/4NPT
	400	20	3/4NPT	19	82.5	63.5	32	36	02016#37	G2MCN20/3/4NPT
	400	20	1NPT	24	88.5	70.5	36	36	02016#38	G2MCN20/1NPT
	400	25	1NPT	24	90	72	41	46	02016#39	G2MCN25S/1NPT
	400	25	1 1/4NPT	25	92	73	46	46	02016#40	G2MCN25S/1 1/4NPT
	400	30	1 1/4NPT	25	95.5	78.5	46	50	02016#41	G2MCN35S/1 1/4NPT
	400	30	1 1/2NPT	26	98.5	80.5	50	50	02016#42	G2MCN35S/1 1/2NPT

**G2WC**

焊接管接头

Butt-Welding Connector

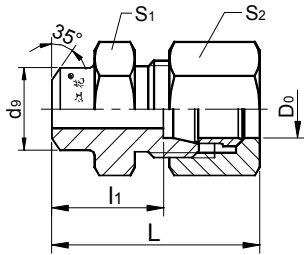

系列	PN	D0	d9	l1	L	S1	S2	产品编号	型号
Series	PN	D0	d9	l1	L	S1	S2	Product No.	Type
L	315	6	10	14	31	14	14	02017#01	G2WC06L
	315	8	12	16	33.5	14	17	02017#02	G2WC08L
	315	10	14	18	37	17	19	02017#03	G2WC10L
	315	12	16	18	37.5	19	22	02017#04	G2WC12L
	315	15	19	22	42	24	27	02017#06	G2WC15L
	315	18	22	23.5	44	27	32	02017#08	G2WC18L
	160	22	27	28.5	52	32	36	02017#10	G2WC22L
	160	28	32	30.5	54.5	41	41	02017#12	G2WC28L
	160	35	40	32.5	59	46	50	02017#15	G2WC35L
	160	42	46	35	63.5	55	60	02017#17	G2WC42L
S	400	6	11	19	36.5	15	17	02017#18	G2WC06S
	400	8	13	21	39.5	17	19	02017#19	G2WC08S
	400	10	15	22.5	42.5	19	22	02017#20	G2WC10S
	400	12	17	24.5	44.5	22	24	02017#21	G2WC12S
	400	14	19	27	48.5	24	27	02017#22	G2WC14S
	400	16	21	26.5	48.5	27	30	02017#23	G2WC16S
	400	20	26	29.5	55.5	32	36	02017#25	G2WC20S
	400	25	31	32	60	41	46	02017#27	G2WC25S
	400	30	36	35.5	67.5	46	50	02017#29	G2WC30S

**G2WBU**

焊接隔壁管接头

Weld Bulkhead Union

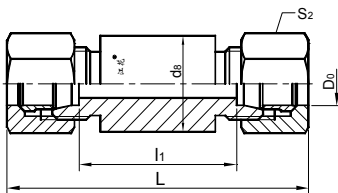

系列	PN	D0	d8	l1	L	S2	产品编号	型号
Series	PN	D0	d8	l1	L	S2	Product No.	Type
L	315	6	18	56	90	14	02018#01	G2WBU06L
	315	8	20	56	91	17	02018#02	G2WBU08L
	315	10	22	58	96	19	02018#03	G2WBU10L
	315	12	25	58	97	22	02018#04	G2WBU12L
	315	15	28	70	110	27	02018#05	G2WBU15L
	315	18	32	69	110	32	02018#06	G2WBU18L
	160	22	36	73	120	36	02018#07	G2WBU22L
	160	28	40	73	121	41	02018#08	G2WBU28L
	160	35	50	71	124	50	02018#09	G2WBU35L
	160	42	60	70	125	60	02018#10	G2WBU42L
S	400	6	20	60	95	17	02018#11	G2WBU06S
	400	8	22	60	97	19	02018#12	G2WBU08S
	400	10	25	59	99	22	02018#13	G2WBU10S
	400	12	28	59	99	24	02018#14	G2WBU12S
	400	14	30	72	115	27	02018#15	G2WBU14S
	400	16	35	71	115	30	02018#16	G2WBU16S
	400	20	38	71	123	36	02018#17	G2WBU20S
	400	25	45	72	128	46	02018#18	G2WBU25S
	400	30	50	73	137	50	02018#19	G2WBU30S



## G2FCM

直通内螺纹接头—公制螺纹

Female Connector—Metric thread

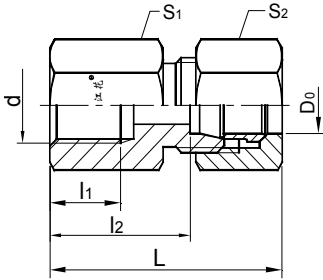

系列	PN	D0	d	l1	l2	L	S1	S2	产品编号	型号
Series	PN	D0	d	l1	l2	L	S1	S2	Product No.	Type
L	315	6	M10×1	10	19.5	36.5	14	14	02019#01	G2FCM06L
	315	8	M12×1.5	14	24	41.5	17	17	02019#02	G2FCM08L
	315	10	M14×1.5	14	25	44	19	19	02019#03	G2FCM10L
	315	12	M16×1.5	14	26	45.5	22	22	02019#04	G2FCM12L
	315	15	M18×1.5	14	28	48	24	27	02019#05	G2FCM15L
	315	18	M22×1.5	16	29.5	50	30	32	02019#06	G2FCM18L
	160	22	M27×2	18	34.5	58	32	36	02019#07	G2FCM22L
	160	28	M33×2	20	37.5	61.5	41	41	02019#08	G2FCM28L
	160	35	M42×2	22	40.5	67	55	50	02019#09	G2FCM35L
	160	42	M48×2	24	42	69.5	60	60	02019#10	G2FCM42L
S	400	6	M12×1.5	14	26	43.5	17	17	02019#11	G2FCM06S
	400	8	M14×1.5	14	26	44.5	19	19	02019#12	G2FCM08S
	400	10	M16×1.5	14	26.5	46.5	22	22	02019#13	G2FCM10S
	400	12	M18×1.5	14	27.5	47.5	24	24	02019#14	G2FCM12S
	400	14	M20×1.5	16	31	52.5	27	27	02019#15	G2FCM14S
	400	16	M22×1.5	16	30.5	52.5	30	30	02019#16	G2FCM16S
	400	20	M27×2	18	34.5	60.5	36	36	02019#17	G2FCM20S
	400	25	M33×2	20	37	65	41	45	02019#18	G2FCM25S
	400	30	M42×2	22	41.5	73.5	55	50	02019#19	G2FCM32S

## G2FCG

直通内螺纹接头—BSPP螺纹

Female Connector—BSPP thread

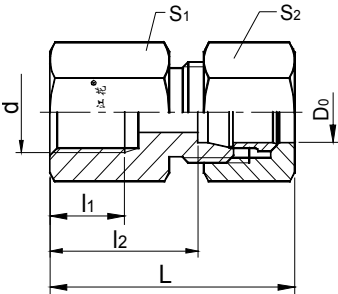

系列	PN	D0	d	l1	l2	L	S1	S2	产品编号	型号
Series	PN	D0	d	l1	l2	L	S1	S2	Product No.	Type
L	315	6	G1/8	10	19	36	14	14	02020#01	G2FCG06L
	315	6	G1/4	14	24	41	19	14	02020#02	G2FCG06L/G1/4
	315	8	G1/4	14	24	41.5	19	17	02020#03	G2FCG08L
	315	8	G3/8	14	25	42.5	24	17	02020#04	G2FCG08L/G3/8
	315	8	G1/2	16	29	46.5	27	17	02020#05	G2FCG08L/G1/2
	315	10	G1/4	14	25	44	19	19	02020#06	G2FCG10L
	315	10	G3/8	14	26	45	24	19	02020#07	G2FCG10L/G3/8
	315	10	G1/2	16	30	49	27	19	02020#08	G2FCG10L/G1/2
	315	12	G3/8	14	26	45.5	24	22	02020#09	G2FCG12L
	315	12	G1/2	16	30	49.5	27	22	02020#10	G2FCG12L/G1/2
	315	15	G1/2	16	31	51	27	27	02020#11	G2FCG15L
	315	18	G1/2	16	30.5	51	27	32	02020#12	G2FCG18L
	160	22	G3/4	18	35.5	59	36	36	02020#13	G2FCG22L
	160	28	G1	20	38	62	41	41	02020#14	G2FCG28L
	160	35	G1 1/4	22	41	67.5	55	50	02020#15	G2FCG35L
	160	42	G1 1/2	24	42.5	70	60	60	02020#16	G2FCG42L
S	400	6	G1/4	14	26	43.5	19	17	02020#17	G2FCG06S
	400	8	G1/4	14	26	44.5	19	19	02020#18	G2FCG08S
	400	10	G3/8	14	26.5	46.5	24	22	02020#19	G2FCG10S
	400	12	G3/8	14	26.5	46.5	24	24	02020#20	G2FCG12S
	400	14	G1/2	16	32	53.5	30	27	02020#21	G2FCG14S
	400	16	G1/2	16	31.5	53.5	30	30	02020#22	G2FCG16S
	400	20	G3/4	18	34.5	60.5	36	36	02020#23	G2FCG20S
	400	25	G1	20	37.5	65.5	41	46	02020#24	G2FCG25S
	250	30	G1 1/4	22	42	74	55	50	02020#25	G2FCG30S

## G2FCN

直通内螺纹接头—NPT螺纹

Female Connector—NPT Thread

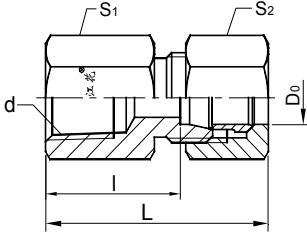

系列	PN	D0	d	l	L	S1	S2	产品编号	型号
Series	PN	D0	d	l	L	S1	S2	Product No.	Type
L	250 6	6	1/8NPT	19	36	14	14	02021#01	G2FCN06L/1/8NPT
	250 6	6	1/4NPT	23.5	40.5	19	14	02021#02	G2FCN06L/1/4NPT
	250 8	8	1/4NPT	23.5	41	19	17	02021#03	G2FCN08L/1/4NPT
	250 10	10	1/4NPT	24	43	19	19	02021#04	G2FCN10L/1/4NPT
	250 12	12	3/8NPT	27	46.5	24	22	02021#05	G2FCN12L/3/8NPT
	250 12	12	1/2NPT	32	51.5	27	22	02021#06	G2FCN12L/1/2NPT
	250 15	15	1/2NPT	33	53	27	27	02021#07	G2FCN15L/1/2NPT
	250 18	18	1/2NPT	32.5	53	27	32	02021#08	G2FCN18L/1/2NPT
	160 22	22	3/4NPT	35.5	59	36	36	02021#09	G2FCN22L/3/4NPT
	160 28	28	1NPT	40.5	64.5	41	41	02021#10	G2FCN28L/1NPT
	160 35	35	1 1/4NPT	40.5	67	55	50	02021#11	G2FCN35L/1 1/4NPT
	160 42	42	1 1/2NPT	42	69.5	60	60	02021#12	G2FCN42L/1 1/2NPT
S	400 6	6	1/8NPT	22	39.5	14	17	02021#13	G2FCN06S/1/8NPT
	400 6	6	1/4NPT	26	43.5	19	17	02021#14	G2FCN06S/1/4NPT
	400 8	8	1/4NPT	26	44.5	19	19	02021#15	G2FCN08S/1/4NPT
	400 10	10	3/8NPT	27	47	24	22	02021#16	G2FCN10S/3/8NPT
	400 12	12	1/4NPT	25	45	22	24	02021#17	G2FCN12S/1/4NPT
	400 12	12	3/8NPT	27.5	47.5	24	24	02021#18	G2FCN12S3/8NPT
	400 12	12	1/2NPT	33.5	53.5	27	24	02021#19	G2FCN12S/1/2NPT
	400 14	14	1/2NPT	35	56.5	27	27	02021#20	G2FCN14S/1/2NPT
	400 16	16	1/2NPT	34.5	56.5	27	30	02021#21	G2FCN16S/1/2NPT
	400 20	20	1/2NPT	33.5	59.5	32	36	02021#22	G2FCN20S/1/2NPT
	400 20	20	3/4NPT	35.5	61.5	36	36	02021#23	G2FCN20S/3/4NPT
	400 25	25	1NPT	41	69	41	46	02021#24	G2FCN25S/1NPT
	400 30	30	1 1/4NPT	43.5	75.5	55	50	02021#25	G2FCN30S/1 1/4NPT

## G2GAM

压力表接头—公制螺纹

Gauge Adapters—Metric Thread

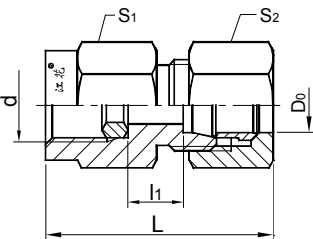

系列	PN	D0	M	l1	L	S1	S2	产品编号	型号
Series	PN	D0	M	l1	L	S1	S2	Product No.	Type
L	250 6	6	M14×1.5	7.5	39	19	14	02022#01	G2GAM06L/M14×1.5
	250 6	6	M20×1.5	8.5	44.5	24	14	02022#02	G2GAM06L/M20×1.5
	250 12	12	M14×1.5	9	43	19	22	02022#03	G2GAM12L/M14×1.5
	250 12	12	M20×1.5	10	48.5	24	22	02022#04	G2GAM12L/M20×1.5
S	400 6	6	M14×1.5	11	43	19	17	02022#05	G2GAM06S/M14×1.5
	400 6	6	M20×1.5	11	47.5	27	17	02022#06	G2GAM06S/M20×1.5
	400 14	14	M14×1.5	12	48	24	27	02022#07	G2GAM14S/M14×1.5
	400 14	14	M20×1.5	12	52.5	27	27	02022#08	G2GAM14S/M20×1.5

**G2GAG**

压力表接头—BSPP (G) 螺纹

Gauge Adapters—BSPP thread

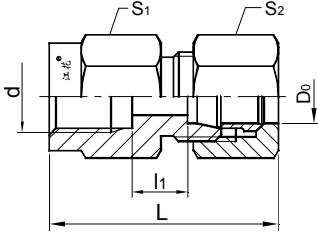

系列	PN	D0	d	l1	L	S1	S2	产品编号	型号
Series	PN	D0	d	l1	L	S1	S2	Product No.	Type
L	315	6	G1/4	7.5	39	19	14	02023#01	G2GAG06L
	315	8	G1/4	7.5	39.5	19	17	02023#02	G2GAG08L
	315	10	G1/4	8.5	42	19	19	02023#03	G2GAG10L
	315	12	G1/4	8.5	42.5	19	22	02023#04	G2GAG12L
S	400	6	G1/2	11	47.5	27	17	02023#05	G2GAG06S
	400	8	G1/2	11	48.5	27	19	02023#06	G2GAG08S
	400	10	G1/2	11.5	50.5	27	22	02023#07	G2GAG10S
	400	12	G1/2	11.5	50.5	27	24	02023#08	G2GAG12S
	400	14	G1/2	12	52.5	27	27	02023#09	G2GAG14S

**G2AGAG**

对接压力表接头—BSPP螺纹

Adjustable Gauge Adapters—BSPP thread

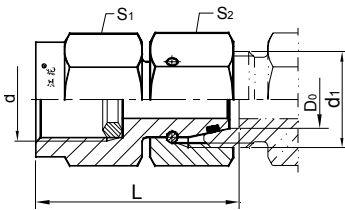

系列	PN	D0	d	d1	L	S1	S2	产品编号	型号
Series	PN	D0	d	d1	L	S1	S2	Product No.	Type
L	315	6	G1/4	M12×1.5	35.5	19	14	02024#01	G2AGAG06L
	315	8	G1/4	M14×1.5	35.5	19	17	02024#02	G2AGAG08L
	315	10	G1/4	M16×1.5	36	19	19	02024#03	G2AGAG10L
	315	12	G1/4	M18×1.5	36	19	22	02024#04	G2AGAG12L
S	400	6	G1/4	M14×1.5	35.5	19	17	02024#05	G2AGAG06S/G1/4
	400	8	G1/4	M16×1.5	35.5	19	19	02024#06	G2AGAG08S/G1/4
	400	10	G1/4	M18×1.5	36	19	22	02024#07	G2AGAG10S/G1/4
	400	12	G1/4	M20×1.5	36	19	24	02024#08	G2AGAG12S/G1/4
	400	6	G1/2	M14×1.5	42.5	27	17	02024#09	G2AGAG06S/G1/2
	400	8	G1/2	M16×1.5	43	27	19	02024#10	G2AGAG08S/G1/2
	400	10	G1/2	M18×1.5	43.5	27	22	02024#11	G2AGAG10S/G1/2
	400	12	G1/2	M20×1.5	45	27	24	02024#12	G2AGAG12S/G1/2
	400	14	G1/2	M20×1.5	45	27	27	02024#13	G2AGAG14S/G1/2

**G2AMCME**

端直通组合接头—公制螺纹U型圈密封(型式E)

Adjustable Male Connector—Metric Thread with U-ring Seal Type E

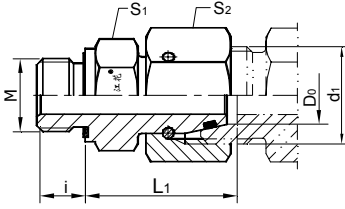

系列	管径			螺纹				产品编号	型号
Series	PN	D0	M	d1	i	L1	S1	S2	Product No. Type
L	250	6	M10×1	M12×1.5	8	24.5	14	14	02025#01 G2AMCME06L
	250	8	M12×1.5	M14×1.5	12	26.5	17	17	02025#02 G2AMCME08L
	250	10	M14×1.5	M16×1.5	12	27.5	19	19	02025#03 G2AMCME10L
	250	12	M16×1.5	M18×1.5	12	30.5	22	22	02025#04 G2AMCME12L
	250	15	M18×1.5	M22×1.5	12	31.5	24	27	02025#05 G2AMCME15L
	250	18	M22×1.5	M24×1.5	14	31.5	27	32	02025#06 G2AMCME18L
	160	22	M27×2	M30×2	16	32.5	32	36	02025#07 G2AMCME22L
	160	28	M33×2	M36×2	18	35	41	41	02025#08 G2AMCME28L
	160	35	M42×2	M45×2	20	42.5	50	50	02025#09 G2AMCME35L
	160	42	M48×2	M52×2	22	46.5	55	60	02025#10 G2AMCME42L
S	400	6	M12×1.5	M14×1.5	12	27	17	17	02025#11 G2AMCME06S
	400	8	M14×1.5	M16×1.5	12	29.5	19	19	02025#12 G2AMCME08S
	400	10	M16×1.5	M18×1.5	12	32	22	22	02025#13 G2AMCME10S
	400	12	M18×1.5	M20×1.5	12	34	24	24	02025#14 G2AMCME12S
	400	14	M20×1.5	M22×1.5	14	36.5	27	27	02025#15 G2AMCME14S
	400	16	M22×1.5	M24×1.5	14	37	27	30	02025#16 G2AMCME16S
	400	20	M27×2	M30×2	16	43	32	36	02025#17 G2AMCME20S
	400	25	M33×2	M36×2	18	48	41	46	02025#18 G2AMCME25S
400	30	M42×2	M42×2	20	51	50	50	02025#19 G2AMCME30S	

**G2AMCGE**

端直通组合接头—BSPP螺纹U型圈密封(型式E)

Adjustable Male Connector—BSPP Thread with U-ring Seal Type E

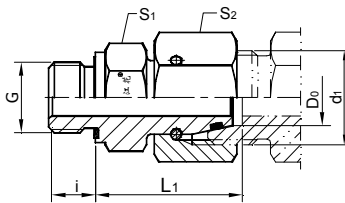

系列	管子外径		螺纹				产品编号	型号	
Series	PN	Tube G	d1	i	L1	S1	S2	Product No. Type	
L	250	6	G1/8A	M12×1.5	8	24.5	14	14	02026#01 G2AMCME06L
	250	8	G1/4A	M14×1.5	12	29.5	19	17	02026#02 G2AMCME08L
	250	10	G1/4A	M16×1.5	12	27.5	19	19	02026#03 G2AMCME10L
	250	12	G3/8A	M18×1.5	12	34	22	22	02026#04 G2AMCME12L
	250	15	G1/2A	M22×1.5	14	32	27	27	02026#05 G2AMCME15L
	250	18	G1/2A	M24×1.5	14	31.5	27	32	02026#06 G2AMCME18L
	160	22	G3/4A	M30×2	16	32.5	32	36	02026#07 G2AMCME22L
	160	28	G1A	M36×2	18	35	41	41	02026#08 G2AMCME28L
	160	35	G11/4A	M45×2	20	42.5	50	50	02026#09 G2AMCME35L
	160	42	G11/2A	M52×2	22	46.5	55	60	02026#10 G2AMCME42L
S	400	6	G1/4A	M14×1.5	12	27	19	17	02026#11 G2AMCME06S
	400	8	G1/4A	M16×1.5	12	29.5	19	19	02026#12 G2AMCME08S
	400	10	G3/8A	M18×1.5	12	32	22	22	02026#13 G2AMCME10S
	400	12	G3/8A	M20×1.5	12	34	22	24	02026#14 G2AMCME12S
	400	14	G1/2A	M22×1.5	14	36.5	27	27	02026#15 G2AMCME14S
	400	16	G1/2A	M24×1.5	14	37	27	30	02026#16 G2AMCME16S
	400	20	G3/4A	M30×2	16	43	32	36	02026#17 G2AMCME20S
	400	25	G1A	M36×2	18	48	41	46	02026#18 G2AMCME25S
400	30	G11/4A	M42×2	20	51	50	50	02026#19 G2AMCME30S	

## G2AMCMF

端直通组合接头—公制螺纹O型圈密封(ISO 6149 型式F)

Adjustable Male Connector—Metric Thread with O-ring Seal Type F

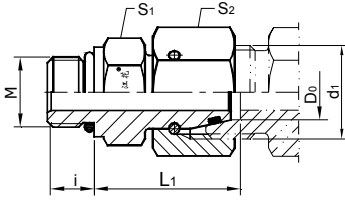

系列				螺纹				产品编号		型号
Series	PN	D0	M	d1	i	L1	S1	S2	Product No.	Type
L	250	6	M10×1	M12×1.5	8.5	24.5	14	14	02027#01	G2AMCMF06L
	250	8	M12×1.5	M14×1.5	11	26.5	17	17	02027#02	G2AMCMF08L
	250	10	M14×1.5	M16×1.5	11	27.5	19	19	02027#03	G2AMCMF10L
	250	12	M16×1.5	M18×1.5	11.5	30.5	22	22	02027#04	G2AMCMF12L
	250	15	M18×1.5	M22×1.5	12.5	31.5	24	27	02027#05	G2AMCMF15L
	250	18	M22×1.5	M24×1.5	13	31.5	27	32	02027#06	G2AMCMF18L
	160	22	M27×2	M30×2	16	32.5	32	36	02027#07	G2AMCMF22L
	160	28	M33×2	M36×2	16	35	41	41	02027#08	G2AMCMF28L
	160	35	M42×2	M45×2	16	42.5	50	50	02027#09	G2AMCMF35L
	160	42	M48×2	M52×2	17.5	46.5	55	60	02027#10	G2AMCMF42L
S	400	6	M12×1.5	M14×1.5	11	27	17	17	02027#11	G2AMCMF06S
	400	8	M14×1.5	M16×1.5	11	29.5	19	19	02027#12	G2AMCMF08S
	400	10	M16×1.5	M18×1.5	12.5	32	22	22	02027#13	G2AMCMF10S
	400	12	M18×1.5	M20×1.5	14	34	24	24	02027#14	G2AMCMF12S
	400	16	M22×1.5	M24×1.5	15	37	27	30	02027#15	G2AMCMF16S
	400	20	M27×2	M30×2	18.5	43	32	36	02027#16	G2AMCMF20S
	400	25	M33×2	M36×2	18.5	48	41	46	02027#17	G2AMCMF25S
	400	30	M42×2	M42×2	19	51	50	50	02027#18	G2AMCMF30S

## G2AMCN

端直通组合接头—NPT螺纹

Adjustable Male Connector—NPT Thread

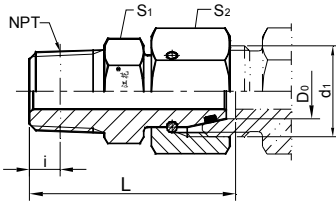

系列				螺纹				产品编号		型号
Series	PN	D0	NPT	d1	i	L	S1	S2	Product No.	Type
L	315	6	1/8NPT	M12×1.5	4.1	31.5	12	14	02028#01	G2AMCN06L
	315	8	1/4NPT	M14×1.5	5.8	37.5	14	17	02028#02	G2AMCN08L
	315	10	1/4NPT	M16×1.5	5.8	38	14	19	02028#03	G2AMCN10L
	315	12	3/8NPT	M18×1.5	6.1	40	19	22	02028#04	G2AMCN12L
	315	15	1/2NPT	M22×1.5	8.1	49	22	27	02028#05	G2AMCN15L
	315	18	1/2NPT	M24×1.5	8.1	49	24	32	02028#06	G2AMCN18L
	160	22	3/4NPT	M30×2	8.6	52	27	36	02028#07	G2AMCN22L
	160	28	1NPT	M36×2	10.2	61	36	41	02028#08	G2AMCN28L
	160	35	1 1/4NPT	M45×2	10.7	65.5	46	50	02028#09	G2AMCN35L
	160	42	1 1/2NPT	M52×2	10.7	68.5	50	60	02028#10	G2AMCN42L
S	400	6	1/4NPT	M14×1.5	5.8	37.5	14	17	02028#11	G2AMCN06S
	400	8	1/4NPT	M16×1.5	5.8	38	14	19	02028#12	G2AMCN08S
	400	10	3/8NPT	M18×1.5	6.1	40.5	19	22	02028#13	G2AMCN10S
	400	12	3/8NPT	M20×1.5	6.1	42	19	24	02028#14	G2AMCN12S
	400	14	1/2NPT	M22×1.5	8.1	50.5	22	27	02028#15	G2AMCN14S
	400	16	1/2NPT	M24×1.5	8.1	51	22	30	02028#16	G2AMCN16S
	400	20	3/4NPT	M30×2	8.6	54	27	36	02028#17	G2AMCN20S
	400	25	1NPT	M36×2	10.2	63.5	36	46	02028#18	G2AMCN25S
	400	30	1 1/4NPT	M42×2	10.7	70.5	46	50	02028#19	G2AMCN30S

## G2AUR

组合变径接头—带密封锥体和O形圈

Adjustable Union Reducing—with Taper and O-ring

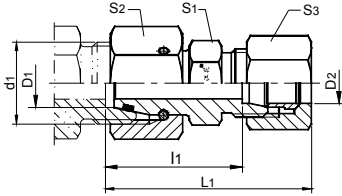

系列	产品编号									型号	
Series	PN	D1	D2	d1	l1	L1	S1	S2	S3	Product No.	Type
L	250	8	6	M14×1.5	24.5	42	14	17	14	02029#01	G2AUR08/06L
	250	10	6	M16×1.5	26	43	14	19	14	02029#02	G2AUR10/06L
			8		27.5	47.5			17	02029#03	G2AUR10/08L
	250	12	6	M18×1.5	26	43	17	22	14	02029#04	G2AUR12/06L
			8		27.5	47.5			17	02029#05	G2AUR12/08L
			10		28	48			19	02029#06	G2AUR12/10L
	250	15	6	M22×1.5	29.5	46.5	19	27	14	02029#07	G2AUR15/06L
			8		31	51			17	02029#08	G2AUR15/08L
			10		31.5	51.5			19	02029#09	G2AUR15/10L
			12		31.5	51.5			22	02029#10	G2AUR15/12L
	250	18	6	M24×1.5	29	46	24	30	14	02029#11	G2AUR18/06L
			8		30.5	50.5			17	02029#12	G2AUR18/08L
			10		31	51			19	02029#13	G2AUR18/10L
			12		31	51			22	02029#14	G2AUR18/12L
			15		31	52			27	02029#15	G2AUR18/15L
	160	22	6	M30×2	33	50	27	36	14	02029#16	G2AUR22/06L
			8		34.5	54.5			17	02029#17	G2AUR22/08L
			10		35	55			19	02029#18	G2AUR22/10L
			12		35	55			22	02029#19	G2AUR22/12L
			15		35	56			27	02029#20	G2AUR22/15L
			18		35	56			32	02029#21	G2AUR22/18L
	160	28	6	M36×2	35	52	32	41	14	02029#22	G2AUR28/06L
			8		36.5	56.5			17	02029#23	G2AUR28/08L
			10		37	57			19	02029#24	G2AUR28/10L
			12		37	57			22	02029#25	G2AUR28/12L
			15		37	58			27	02029#26	G2AUR28/15L
			18		37	58			32	02029#27	G2AUR28/18L
			22		39.5	63.5			32	41	36
	160	35	10	M45×2	40	60	41	50	19	02029#29	G2AUR35/10L
			12		40	60			22	02029#30	G2AUR35/12L
			15		40	61			27	02029#31	G2AUR35/15L
			18		40	61			32	02029#32	G2AUR35/18L
			22		42.5	66.5			36	02029#33	G2AUR35/22L
	160	42	15	M52×2	43.5	64.5	50	60	27	02029#35	G2AUR42/15L
			18		43.5	64.5			32	02029#36	G2AUR42/18L
			22		46	70			36	02029#37	G2AUR42/22L
			28		46	71.5			41	02029#38	G2AUR42/28L
			35		46	73			50	02029#39	G2AUR42/35L

## G2AUR

组合变径接头—带密封锥体和O形圈

Adjustable Union Reducing—with Taper and O-ring

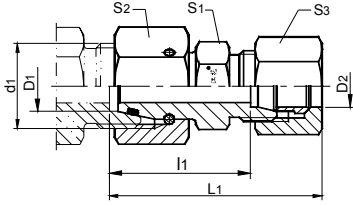

系列	产品编号									型号	
Series	PN	D1	D2	d1	l1	L1	S1	S2	S3	Product No.	Type
S	400	8	6	M16×1.5	28.5	46.5	14	19	17	02029#40	G2AUR08/06S
	400	10	6	M18×1.5	29	47	17	22	17	02029#41	G2AUR10/06S
			8		29	48		19	02029#42	G2AUR10/08S	
	400	12	6	M20×1.5	30.5	48.5	17	24	17	02029#43	G2AUR12/06S
			8		30.5	49.5	17	19	02029#44	G2AUR12/08S	
			10		30.5	51.5	19	22	02029#45	G2AUR12/10S	
	400	14	6	M22×1.5	33	51	19	27	17	02029#46	G2AUR14/06S
			8		33	52	19	19	02029#47	G2AUR14/08S	
			10		32	53	19	22	02029#48	G2AUR14/10S	
			12		32.5	53.5	22	24	02029#49	G2AUR14/12S	
	400	16	6	M24×1.5	33.5	51.5	22	30	17	02029#50	G2AUR16/06S
			8		33.5	52.5	22	19	02029#51	G2AUR16/08S	
			10		32.5	53.5	22	22	02029#52	G2AUR16/10S	
			12		33	54	22	24	02029#53	G2AUR16/12S	
			14		33	55	24	27	02029#54	G2AUR16/14S	
	400	20	6	M30×2	37.5	55.5	27	36	17	02029#55	G2AUR20/06S
			8		37.5	56.5		19	02029#56	G2AUR20/08S	
			10		36.5	57.5		22	02029#57	G2AUR20/10S	
			12		37	58		24	02029#58	G2AUR20/12S	
			14		37	59		27	02029#59	G2AUR20/14S	
	400	25	6	M36×2	40	58	32	46	17	02029#61	G2AUR25/06S
			8		40	59		19	02029#62	G2AUR25/08S	
			10		39	60		22	02029#63	G2AUR25/10S	
			12		39.5	60.5		24	02029#64	G2AUR25/12S	
			14		39.5	61.5		27	02029#65	G2AUR25/14S	
15			39.5		61.5		30	02029#66	G2AUR25/16S		
20			39		66		36	02029#67	G2AUR25/20S		
400	30	6	M42×2	45.5	63.5	41	50	17	02029#68	G2AUR30/06S	
		8		45.5	64.5		19	02029#69	G2AUR30/08S		
		10		44.5	65.5		22	02029#70	G2AUR30/10S		
		12		45	66		24	02029#71	G2AUR30/12S		
		14		45	67		27	02029#72	G2AUR30/14S		
		16		45	67		30	02029#73	G2AUR30/16S		
		20		44.5	71.5		36	02029#74	G2AUR30/20S		
		25		45	73.5		46	02029#75	G2AUR30/25S		

**G2SU**

组合直通接头—双侧带密封锥体和O形圈

Swivel Union—with Taper and O-ring on Both Ends

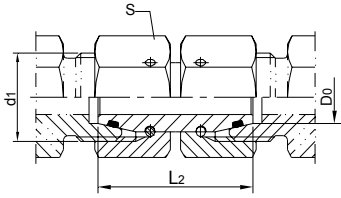

系列	PN	D0	d1	L2	S	产品编号	型号
Series	PN	D0	d1	L2	S	Product No.	Type
L	250	6	M12×1.5	32	14	02030#01	G2SU06L
	250	8	M14×1.5	32	17	02030#02	G2SU08L
	250	10	M16×1.5	33	19	02030#03	G2SU10L
	250	12	M18×1.5	33	22	02030#04	G2SU12L
	250	15	M22×1.5	38	27	02030#05	G2SU15L
	250	18	M24×1.5	36	32	02030#06	G2SU18L
	160	22	M30×2	42	36	02030#07	G2SU22L
	160	28	M36×2	46	41	02030#08	G2SU28L
	160	35	M45×2	48	50	02030#09	G2SU35L
	160	42	M52×2	52	60	02030#10	G2SU42L
S	400	6	M14×1.5	32	17	02030#11	G2SU06S
	400	8	M16×1.5	33	19	02030#12	G2SU08S
	400	10	M18×1.5	33	22	02030#13	G2SU10S
	400	12	M20×1.5	36	24	02030#14	G2SU12S
	400	14	M22×1.5	39	27	02030#15	G2SU14S
	400	16	M24×1.5	39	30	02030#16	G2SU16S
	400	20	M30×2	44	36	02030#17	G2SU20S
	400	25	M36×2	46	46	02030#18	G2SU25S
	400	30	M42×2	52	50	02030#19	G2SU30S

**G2SUR**

组合转换接头—双侧带密封锥体和O形圈

Swivel Union Reducer—with Taper and O-ring on Both Ends

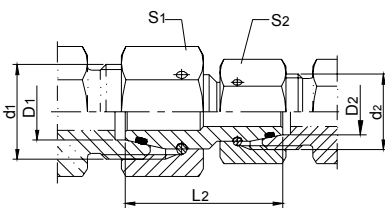

系列	PN	D1	D2	d1	d2	L2	S1	S2	产品编号	型号
Series	PN	D1	D2	d1	d2	L2	S1	S2	Product No.	Type
S/L	250	6	6	M14×1.5	M12×1.5	32	17	14	02031#01	G2SUR06S/06L
	250	8	8	M16×1.5	M14×1.5	33	19	17	02031#02	G2SUR08S/08L
	250	10	10	M18×1.5	M16×1.5	33	22	19	02031#03	G2SUR10S/10L
	250	12	12	M20×1.5	M18×1.5	36	24	22	02031#04	G2SUR12S/12L
	250	16	15	M24×1.5	M22×1.5	39	30	27	02031#05	G2SUR16S/15L
	250	20	18	M30×2	M24×1.5	44	36	32	02031#06	G2SUR20S/18L
	160	25	22	M36×2	M30×2	46	41	36	02031#07	G2SUR25S/22L
	160	30	28	M42×2	M36×2	52	50	41	02031#08	G2SUR30S/28L
L/S	250	18	16	M24×1.5	M24×1.5	39	32	30	02031#09	G2SUR18L/16S
	160	22	20	M30×2	M30×2	44	36	36	02031#10	G2SUR22L/20S
	160	28	25	M36×2	M36×2	46	41	41	02031#11	G2SUR28L/25S
	160	35	30	M45×2	M42×2	52	50	50	02031#12	G2SUR35L/30S



## G2SUR

组合变径接头—双侧带密封锥体和O形圈

Swivel Union Reducer—with Taper and O-ring on Both Ends

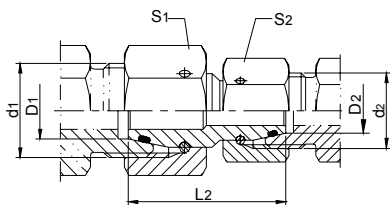

系列	PN	D1	D2	d1	d2	L2	S1	S2	产品编号	型号
Series	PN	D1	D2	d1	d2	L2	S1	S2	Product No.	Type
L	250	8	6	M14×1.5	M12×1.5	32	17	14	02032#01	G2SUR08/06L
	250	10	6	M16×1.5	M12×1.5	33	19	14	02032#02	G2SUR10/06L
			8	M14×1.5	33	17	02032#03	G2SUR10/08L		
	250	12	6	M18×1.5	M12×1.5	33	22	14	02032#04	G2SUR12/06L
			8	M14×1.5	33	17	02032#05	G2SUR12/08L		
			10	M16×1.5	33	19	02032#06	G2SUR12/10L		
	250	15	8	M22×1.5	M14×1.5	38	27	17	02032#07	G2SUR15/08L
			10	M16×1.5	38	19	02032#08	G2SUR15/10L		
			12	M18×1.5	38	22	02032#09	G2SUR15/12L		
	250	18	10	M24×1.5	M16×1.5	36	30	19	02032#10	G2SUR18/10L
			12	M18×1.5	36	22	02032#11	G2SUR18/12L		
			15	M22×1.5	38	27	02032#12	G2SUR18/15L		
	160	22	12	M30×2	M18×1.5	42	36	22	02032#13	G2SUR22/12L
			15	M22×1.5	42	27	02032#14	G2SUR22/15L		
			18	M24×1.5	42	32	02032#15	G2SUR22/18L		
	160	28	15	M36×2	M22×1.5	46	41	27	02032#16	G2SUR28/15L
			18	M24×1.5	46	32	02032#17	G2SUR28/18L		
			22	M30×2	46	36	02032#18	G2SUR28/22L		
160	35	18	M45×2	M24×1.5	48	50	32	02032#19	G2SUR35/18L	
		22	M30×2	48	36	02032#20	G2SUR35/22L			
		28	M36×2	48	41	02032#21	G2SUR35/28L			
160	42	22	M52×2	M30×2	52	60	41	02032#22	G2SUR42/22L	
		28	M36×2	52	50	02032#23	G2SUR42/28L			
		35	M45×2	52	60	02032#24	G2SUR42/35L			
S	400	8	6	M16×1.5	M14×1.5	33	19	17	02032#25	G2SUR08/06S
	400	10	6	M18×1.5	M14×1.5	33	22	17	02032#26	G2SUR10/06S
			8	M16×1.5	33	19	02032#27	G2SUR10/08S		
	400	12	6	M20×1.5	M14×1.5	36	24	17	02032#28	G2SUR12/06S
			8	M16×1.5	36	19	02032#29	G2SUR12/08S		
			10	M18×1.5	36	22	02032#30	G2SUR12/10S		
	400	16	10	M24×1.5	M18×1.5	39	30	22	02032#31	G2SUR16/10S
			12	M20×1.5	39	24	02032#32	G2SUR16/12S		
	400	20	12	M30×2	M20×1.5	44	36	24	02032#33	G2SUR20/12S
			16	M24×1.5	44	30	02032#34	G2SUR20/16S		
400	25	16	M36×2	M24×1.5	46	41	30	02032#35	G2SUR25/16S	
		20	M30×2	46	36	02032#36	G2SUR25/20S			
400	30	16	M42×2	M24×1.5	52	50	30	02032#37	G2SUR30/16S	
		20	M30×2	52	36	02032#38	G2SUR30/20S			
		25	M36×2	52	46	02032#39	G2SUR30/25S			

## G2E

### 直角管接头

### Union Elbow

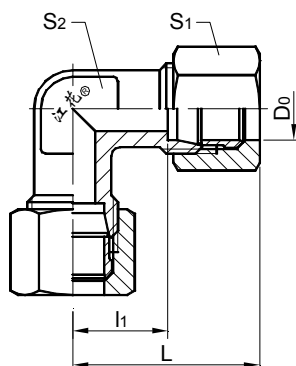

系列	PN	D0	I1	L	S1	S2	产品编号	型号
Series	PN	D0	I1	L	S1	S2	Product No.	Type
L	315	6	12	29	14	12	02033#01	G2E06L
	315	8	14	31.5	17	14	02033#02	G2E08L
	315	10	15	34	19	17	02033#03	G2E10L
	315	12	17	36.5	22	19	02033#04	G2E12L
	315	15	21	41	27	19	02033#05	G2E15L
	315	18	23.5	44	32	24	02033#06	G2E18L
	160	22	27.5	51	36	27	02033#07	G2E22L
	160	28	30.5	54.5	41	36	02033#08	G2E28L
	160	35	34.5	61	50	41	02033#09	G2E35L
	160	42	40	67.5	60	50	02033#10	G2E42L
S	400	6	16	33.5	17	12	02033#11	G2E06S
	400	8	17	35.5	19	14	02033#12	G2E08S
	400	10	17.5	37.5	22	17	02033#13	G2E10S
	400	12	21.5	41.5	24	17	02033#14	G2E12S
	400	14	22	43.5	27	19	02033#15	G2E14S
	400	16	24.5	46.5	30	24	02033#16	G2E16S
	400	20	26.5	52	36	27	02033#17	G2E20S
	400	25	30	58	46	36	02033#18	G2E25S
	400	30	35.5	67.5	50	41	02033#19	G2E30S

## G2BUE

### 隔壁直角管接头

### Bulkhead Union Elbow

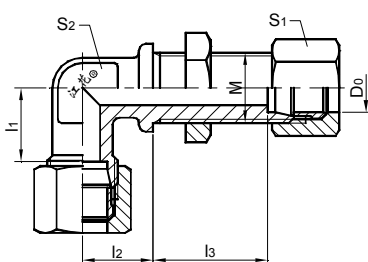

系列	PN	D0	M	I1	I2	I3	S2	产品编号	型号
Series	PN	D0	M	I1	I2	I3	S2	Product No.	Type
L	250	6	M12×1.5	12	14	27	12	02034#01	G2BUE06L
	250	8	M14×1.5	14	17	27	14	02034#02	G2BUE08L
	250	10	M16×1.5	15	18	28	17	02034#03	G2BUE10L
	250	12	M18×1.5	17	20	29	19	02034#04	G2BUE12L
	250	15	M22×1.5	21	23	31	19	02034#05	G2BUE15L
	250	18	M24×1.5	23.5	24	32.5	24	02034#06	G2BUE18L
	160	22	M30×2	27.5	30	34.5	27	02034#07	G2BUE22L
	160	28	M36×2	30.5	34	35.5	36	02034#08	G2BUE28L
	160	35	M45×2	34.5	39	36.5	41	02034#09	G2BUE35L
	160	42	M52×2	40	43	36	50	02034#10	G2BUE42L
S	400	6	M14×1.5	16	17	29	12	02034#11	G2BUE06S
	400	8	M16×1.5	17	18	29	14	02034#12	G2BUE08S
	400	10	M18×1.5	17.5	20	29.5	17	02034#13	G2BUE10S
	400	12	M20×1.5	21.5	21	30.5	17	02034#14	G2BUE12S
	400	14	M22×1.5	22	23	32	19	02034#15	G2BUE14S
	400	16	M24×1.5	24.5	24	31.5	24	02034#16	G2BUE16S
	400	20	M30×2	26.5	30	33.5	27	02034#17	G2BUE20S
	400	25	M36×2	30	34	35	36	02034#18	G2BUE25S
	400	30	M42×2	35.5	39	37.5	41	02034#19	G2BUE30S

**G2MEMA**

端直角接头—公制螺纹垫片密封(型式A)

Male Elbow—Metric Thread with Gasket Seal Type A

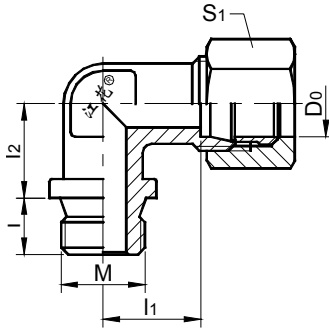

系列	PN	D0	M	i	l1	l2	S1	产品编号	型号
Series	PN	D0	M	i	l1	l2	S1	Product No.	Type
L	315	6	M10×1	8	12	14	14	02035#01	G2MEMA06L
	315	8	M12×1.5	12	14	16	17	02035#02	G2MEMA08L
	315	10	M14×1.5	12	15	17	19	02035#03	G2MEMA10L
	315	12	M16×1.5	12	17	19	22	02035#04	G2MEMA12L
	315	15	M22×1.5	14	21	22	27	02035#05	G2MEMA15L
	315	18	M22×1.5	14	23.5	24	32	02035#06	G2MEMA18L
	160	22	M27×2	16	27.5	27	36	02035#07	G2MEMA22L
	160	28	M33×2	18	30.5	30	41	02035#08	G2MEMA28L
	160	35	M42×2	20	34.5	35	50	02035#09	G2MEMA35L
	160	42	M48×2	22	40	41	60	02035#10	G2MEMA42L
S	400	6	M12×1.5	12	16	16	17	02035#11	G2MEMA06S
	400	8	M14×1.5	12	17	17	19	02035#12	G2MEMA08S
	400	10	M16×1.5	12	17.5	19	22	02035#13	G2MEMA10S
	400	12	M18×1.5	12	21.5	19	24	02035#14	G2MEMA12S
	400	14	M18×1.5	14	22	22	27	02035#15	G2MEMA14S
	400	16	M22×1.5	14	24.5	23	30	02035#16	G2MEMA16S
	400	20	M27×2	16	26.5	27	36	02035#17	G2MEMA20S
	250	25	M33×2	18	30	31	46	02035#18	G2MEMA25S
	160	30	M42×2	20	35.5	34	50	02035#19	G2MEMA30S

**G2MEGA**

端直角接头—英制管螺纹(BSP)垫片密封(型式A)

Male Elbow—Whitworth BSP Thread with Gasket Seal Type A

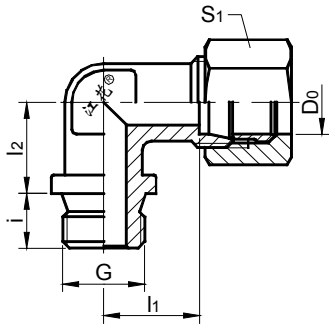

系列	PN	D0	G	i	l1	l2	S1	产品编号	型号
Series	PN	D0	G	i	l1	l2	S1	Product No.	Type
L	315	6	G1/8A	8	12	14	14	02036#01	G2MEGA06L
	315	8	G1/4A	12	14	16	17	02036#02	G2MEGA08L
	315	10	G1/4A	12	15	17	19	02036#03	G2MEGA10L
	315	12	G3/8A	12	17	19	22	02036#04	G2MEGA12L
	315	15	G1/2A	14	21	22	27	02036#05	G2MEGA15L
	315	18	G1/2A	14	23.5	24	32	02036#06	G2MEGA18L
	160	22	G3/4A	16	27.5	27	36	02036#07	G2MEGA22L
	160	28	G1A	18	30.5	30	41	02036#08	G2MEGA28L
	160	35	G11/4A	20	34.5	35	50	02036#09	G2MEGA35L
	160	42	G11/2A	22	40	41	60	02036#10	G2MEGA42L
S	400	6	G1/4A	12	16	16	17	02036#11	G2MEGA06S
	400	8	G1/4A	12	17	17	19	02036#12	G2MEGA08S
	400	10	G3/8A	12	17.5	19	22	02036#13	G2MEGA10S
	400	12	G3/8A	12	21.5	19	24	02036#14	G2MEGA12S
	400	14	G1/2A	14	22	22	27	02036#15	G2MEGA14S
	400	16	G1/2A	14	24.5	23	30	02036#16	G2MEGA16S
	400	20	G3/4A	16	26.5	27	36	02036#17	G2MEGA20S
	250	25	G1A	18	30	31	46	02036#18	G2MEGA25S
	160	30	G11/4A	20	35.5	34	50	02036#19	G2MEGA30S

注: 米制螺纹M终端和BSP圆柱管螺纹终端(型式A)常规采用组合垫片密封,金属平垫也可适用。

NOTE: Metric thread ends M and BSP parallel thread ends (Form A) are typically used with a gasket having a bonded elastomer seal. The flat metal gaskets may also be used.

## G2MEN

端直角管接头—NPT螺纹

Male Elbow—NPT Thread

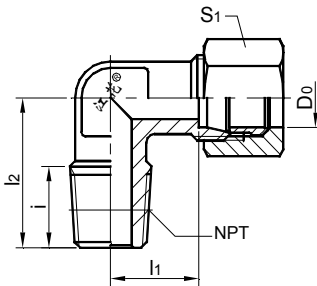

系列	PN	D0	NPT	i	l1	l2	S1	产品编号	型号
Series	PN	D0	NPT	i	l1	l2	S1	Product No	Type
L	315	6	1/8NPT	10	12	20	14	02037#01	G2MEN06L/1/8NPT
	315	8	1/4NPT	14.5	14	26	17	02037#02	G2MEN08L/1/4NPT
	315	10	1/4NPT	14.5	15	27	19	02037#03	G2MEN10L/1/4NPT
	315	12	3/8NPT	15	17	28	22	02037#04	G2MEN12L/3/8NPT
	315	15	1/2NPT	19	21	34	27	02037#05	G2MEN15L/1/2NPT
	315	18	1/2NPT	19	23.5	36	32	02037#06	G2MEN18L/1/2NPT
	160	22	3/4NPT	19	27.5	42	36	02037#07	G2MEN22/3/4NPT
	160	28	1NPT	24	30.5	48	41	02037#08	G2MEN28L/1NPT
	160	35	1 1/4NPT	25	34.5	54	50	02037#09	G2MEN35L/1 1/4NPT
	160	42	1 1/2NPT	26	40	61	60	02037#10	G2MEN42L/1 1/2NPT
S	400	6	1/4NPT	14.5	16	26	17	02037#11	G2MEN06S/1/4NPT
	400	8	1/4NPT	14.5	17	27	19	02037#12	G2MEN08S/1/4NPT
	400	10	3/8NPT	15	17.5	28	22	02037#13	G2MEN10S/3/8NPT
	400	12	3/8NPT	15	22.5	28	24	02037#14	G2MEN12S/3/8NPT
	400	14	1/2NPT	19	22	34	27	02037#15	G2MEN14S/1/2NPT
	400	16	1/2NPT	19	24.5	36	30	02037#16	G2MEN16S/1/2NPT
	400	20	3/4NPT	19	26.5	42	36	02037#17	G2MEN20S/3/4NPT
	400	25	1NPT	24	30	48	46	02037#18	G2MEN25S/1NPT
	400	30	1 1/4NPT	25	35.5	54	50	02037#19	G2MEN30S/1 1/4NPT

## G2MER

端直角管接头—BSPT(R)英制锥管螺纹

Male Elbow—Whitworth BSP Taper Thread

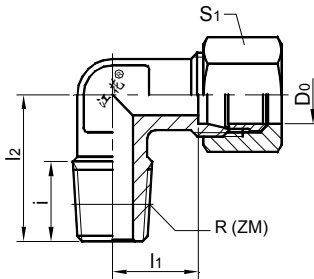

系列	PN	D0	R	i	l1	l2	S1	产品编号	型号
Series	PN	D0	R	i	l1	l2	S1	Product No	Type
L	315	6	R1/8	10	12	20	14	02038#01	G2MER06L/R1/8
	315	8	R1/4	14.5	14	26	17	02038#02	G2MER08L/R1/4
	315	10	R1/4	14.5	15	27	19	02038#03	G2MER10L/R1/4
	315	12	R3/8	15	17	28	22	02038#04	G2MER12L/R3/8
	315	15	R1/2	19	21	34	27	02038#05	G2MER15L/R1/2
	315	18	R1/2	19	23.5	36	32	02038#06	G2MER18L/R1/2
S	400	6	R1/4	10	16	26	17	02038#07	G2MER06L/R1/8
	400	8	R1/4	14.5	17	27	19	02038#08	G2MER08L/R1/4
	400	10	R3/8	15	17.5	28	22	02038#09	G2MER10L/R1/4
	400	12	R3/8	15	22.5	28	24	02038#10	G2MER12L/R3/8
	400	14	R1/2	19	22	34	27	02038#11	G2MER15L/R1/2
	400	16	R1/2	19	24.5	36	30	02038#12	G2MER18L/R1/2

## G2MEZ

端直角管接头—ZM米制锥管螺纹

Male Elbow—Metrical ZM Taper Thread

系列	PN	D0	ZM	i	l1	l2	S1	产品编号	型号
Series	PN	D0	ZM	i	l1	l2	S1	Product No	Type
L	315	6	ZM10	10	12	20	14	02039#01	G2MEZ06L/ZM10
	315	8	ZM14	16	14	26	17	02039#02	G2MEZ08L/ZM14
	315	10	ZM14	16	15	27	19	02039#03	G2MEZ10L/ZM14
	315	12	ZM18	16	17	28	22	02039#04	G2MEZ12L/ZM18
	315	15	ZM22	16	21	34	27	02039#05	G2MEZ15L/ZM22
	315	18	ZM22	16	23.5	36	32	02039#06	G2MEZ18L/ZM22

**G2AMEMF**

可调向端直角管接头—公制螺纹O型圈密封(ISO 6149-1 型式F)

Adjustable Male Elbow—M Thread with O-ring Seal Type F(ISO 6149-1 Ports)

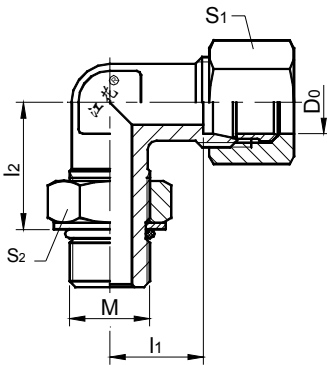

系列	PN	D0	M	l1	l2	S1	S2	产品编号	型号
Series	PN	D0	M	l1	l2	S1	S2	Product No	Type
L	315	6	M10×1	14	20	14	14	02040#01	G2AMEMF06L
	315	8	M12×1.5	16	22	17	17	02040#02	G2AMEMF08L
	315	10	M14×1.5	17	25	19	19	02040#03	G2AMEMF10L
	315	12	M16×1.5	19	26	22	22	02040#04	G2AMEMF12L
	315	15	M18×1.5	21	30	27	24	02040#05	G2AMEMF15L
	250	18	M22×1.5	24	33	32	27	02040#06	G2AMEMF18L
	160	22	M27×2	28	35	36	32	02040#07	G2AMEMF22L
	160	28	M33×2	31	38	41	41	02040#08	G2AMEMF28L
	160	35	M42×2	38	48	50	50	02040#09	G2AMEMF35L
	160	42	M48×2	38	49	60	55	02040#10	G2AMEMF42L
S	315	6	M12×1.5	15	22	17	17	02040#11	G2AMEMF06S
	315	8	M14×1.5	17	26	19	19	02040#12	G2AMEMF08S
	315	10	M16×1.5	18	27	22	22	02040#13	G2AMEMF10S
	315	12	M18×1.5	22	31	24	24	02040#14	G2AMEMF12S
	250	16	M22×1.5	25	35	30	27	02040#15	G2AMEMF16S
	250	20	M27×2	28	39	36	32	02040#16	G2AMEMF20S
	160	25	M33×2	30	44	46	41	02040#17	G2AMEMF25S
	160	30	M42×2	36	51	50	50	02040#18	G2AMEMF30S

**G2AMEUF**

可调向端直角管接头—UN/UNF螺纹O型圈密封(ISO 6149-1 型式F)

Adjustable Male Elbow—UN Thread with O-ring Seal Type F(ISO 6149-1 Ports)

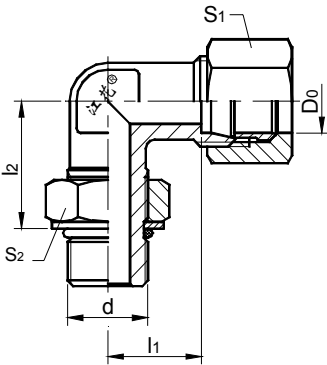

系列	PN	D0	d	l1	l2	S1	S2	产品编号	型号
Series	PN	D0	d	l1	l2	S1	S2	Product No	Type
L	315	6	7/16-20UNF	14	19	15	14	02041#01	G2AMEUF06L
	315	8	7/16-20UNF	16	19	17	14	02041#02	G2AMEUF08L
	315	10	9/16-18UNF	17	24	19	17	02041#03	G2AMEUF10L
	315	12	9/16-18UNF	19	25	22	17	02041#04	G2AMEUF12L
	315	12	3/4-16UNF	19	25	22	22	02041#05	G2AMEUF12L-3/4UNF
	315	15	3/4-16UNF	21	28	27	22	02041#06	G2AMEUF15L
	315	15	7/8-14UNF	21	28	27	27	02041#07	G2AMEUF15L-7/8UNF
	315	18	7/8-14UNF	24	32	30	27	02041#08	G2AMEUF18L
	315	18	1 1/16-12UN	24	32	30	32	02041#09	G2AMEUF18L-1 1/16UN
	160	22	1 1/16-12UN	28	35	36	32	02041#10	G2AMEUF22L
	160	28	1 5/16-12UN	31	42	41	41	02041#11	G2AMEUF28L
	160	35	1 5/8-12UN	38	46	50	50	02041#12	G2AMEUF35L
	160	42	1 7/8-12UN	38	47	60	55	02041#13	G2AMEUF42L
S	400	6	7/16-20UNF	15	20	17	17	02041#14	G2AMEUF06S
	400	8	9/16-18UNF	17	25	19	19	02041#15	G2AMEUF08S
	400	10	9/16-18UNF	18	26	22	22	02041#16	G2AMEUF10S
	400	12	3/4-16UNF	22	30	24	24	02041#17	G2AMEUF12S
	400	16	7/8-14UNF	25	34	30	27	02041#18	G2AMEUF16S
	400	20	1 1/16-12UN	28	37	36	32	02041#19	G2AMEUF20S
	400	25	1 1/16-12UN	30	50	41	41	02041#20	G2AMEUF25S
	250	30	1 5/8-12UN	36	50	50	50	02041#21	G2AMEUF30S

**G2AMEMH**

可调向端直角管接头—公制螺纹O型圈带支承环密封(型式H)

**Adjustable Male Elbow**

—Metric Thread with O-ring and Retaining Ring Seal Type H

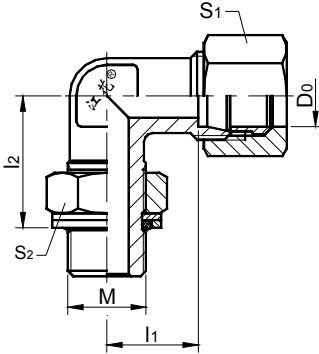

系列	PN	D0	M	l1	l2	S1	S2	产品编号	型号
Series	PN	D0	M	l1	l2	S1	S2	Product No	Type
L	315	6	M10×1	14	20	14	14	02042#01	G2AMEMH06L
	315	8	M12×1.5	16	22	17	17	02042#02	G2AMEMH08L
	315	10	M14×1.5	17	24	19	19	02042#03	G2AMEMH10L
	315	12	M16×1.5	19	25	22	22	02042#04	G2AMEMH12L
	315	15	M18×1.5	21	31	27	24	02042#05	G2AMEMH15L
	250	18	M22×1.5	24	33	32	27	02042#06	G2AMEMH18L
	160	22	M27×2	28	36	36	32	02042#07	G2AMEMH22L
	160	28	M33×2	31	39	41	41	02042#08	G2AMEMH28L
	160	35	M42×2	38	49	50	50	02042#09	G2AMEMH35L
	160	42	M48×2	38	50	60	55	02042#10	G2AMEMH42L
S	315	6	M12×1.5	15	22	17	17	02042#11	G2AMEMH06S
	315	8	M14×1.5	17	26	19	19	02042#12	G2AMEMH08S
	315	10	M16×1.5	18	27	22	22	02042#13	G2AMEMH10S
	315	12	M18×1.5	22	31	24	24	02042#14	G2AMEMH12S
	250	16	M22×1.5	25	36	30	27	02042#15	G2AMEMH16S
	250	20	M27×2	28	39	36	32	02042#16	G2AMEMH20S
	160	25	M33×2	30	44	46	41	02042#17	G2AMEMH25S
	160	30	M42×2	36	51	50	50	02042#18	G2AMEMH30S

**G2AMEGH**

可调向端直角管接头—BSPB螺纹O型圈带支承环密封(ISO 1179-1型式H)

**Adjustable Male Elbow**

—BSPB Thread with O-ring and Retaining Ring Seal Type H(ISO 1179-1 Ports)

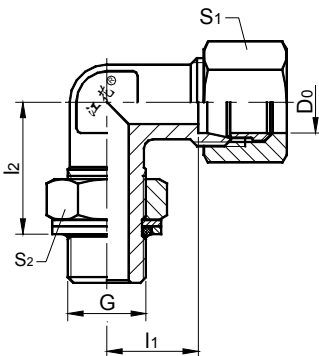

系列	PN	D0	G	l1	l2	S1	S2	产品编号	型号
Series	PN	D0	G	l1	l2	S1	S2	Product No	Type
L	315	6	G1/8A	14	19	15	14	02043#01	G2AMEGH06L
	315	8	G1/4A	16	23	17	19	02043#02	G2AMEGH08L
	315	10	G1/4A	17	25	19	19	02043#03	G2AMEGH10L
	315	12	G3/8A	19	28	22	22	02043#04	G2AMEGH12L
	315	15	G1/2A	21	30	27	27	02043#05	G2AMEGH15L
	250	18	G1/2A	24	36	30	27	02043#06	G2AMEGH18L
	160	22	G3/4A	28	36	36	36	02043#07	G2AMEGH22L
	160	28	G1A	31	44	41	41	02043#08	G2AMEGH28L
	160	35	G1 1/4A	38	50	50	50	02043#09	G2AMEGH35L
	160	42	G1 1/2A	38	52	60	55	02043#10	G2AMEGH42L
S	315	6	G1/4A	15	23	17	19	02043#11	G2AMEGH06S
	315	8	G1/4A	17	27	19	19	02043#12	G2AMEGH08S
	315	10	G3/8A	18	29	22	22	02043#13	G2AMEGH10S
	315	12	G3/8A	22	29	24	2	02043#14	G2AMEGH12S
	250	16	G1/2A	25	36	30	27	02043#15	G2AMEGH16S
	250	20	G3/4A	28	39	36	36	02043#16	G2AMEGH20S
	160	25	G1A	30	44	41	41	02043#17	G2AMEGH25S
	160	30	G1 1/4A	36	49	50	50	02043#18	G2AMEGH30S

**G2AMEMO**

可调向端直角管接头—公制螺纹O形圈密封 (型式0)

Adjustable Male Elbow—Metric Thread with O-ring Seal Type O

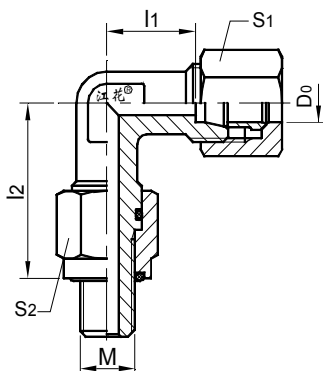

系列	产品编号							型号	
Series	PN	D0	M	l1	l2	S1	S2	Product No	Type
S	400	8	M12×1.5	21	36	19	19	02044#01	G2AMEMO08S
	400	10	M14×1.5	21.5	36	22	24	02044#02	G2AMEMO10S/M14×1.5
	400	10	M16×1.5	21.5	36	22	27	02044#03	G2AMEMO10S/M16×1.5
	400	12	M18×1.5	22.5	39	24	27	02044#04	G2AMEMO12S
	400	16	M22×1.5	24.5	43	30	32	02044#05	G2AMEMO16S
	400	20	M27×2	30	51.5	36	41	02044#06	G2AMEMO20S
	400	25	M33×2	37	61	46	50	02044#07	G2AMEMO25S
	400	30	M42×2	37	63.5	50	60	02044#08	G2AMEMO30S

**G2AMEGO**

可调向端直角管接头—BSPP螺纹O形圈密封 (型式0)

Adjustable Male Elbow—BSPP Thread with O-ring Seal Type O

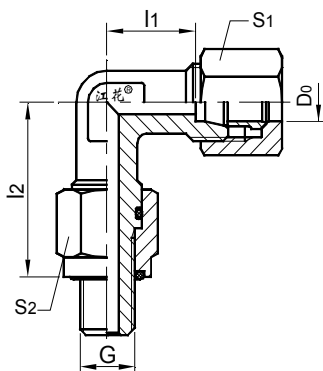

系列	产品编号							型号	
Series	PN	D0	G	l1	l2	S1	S2	Product No	Type
S	400	10	G1/4A	21.5	36	22	24	02045#01	G2AMEGO10S/G1/4A
	400	10	G3/8A	21.5	36	22	27	02045#02	G2AMEGO10S/G3/8A
	400	12	G3/8A	22.5	39	24	27	02045#03	G2AMEGO12S
	400	16	G1/2A	24.5	43	30	32	02045#04	G2AMEGO16S
	400	20	G3/4A	30	51.5	36	41	02045#05	G2AMEGO20S
	400	25	G1A	37	61	41	50	02045#06	G2AMEGO25S
	400	30	G1 1/4A	37	63.5	50	60	02045#07	G2AMEGO30S

**G2AUE**  
组合直角管接头  
Adjustable Union Elbow

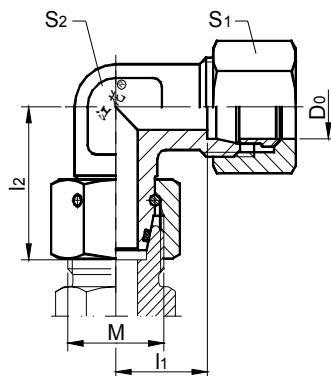

系列 Series	PN	D0	l1	l2	S1	S2	产品编号 Product No	型号 Type
L	315	6	12	26	14	12	02046#01	G2AUE06L
	315	8	14	27.5	17	12	02046#02	G2AUE08L
	315	10	15	29	19	14	02046#03	G2AUE10L
	315	12	17	29.5	22	17	02046#04	G2AUE12L
	315	15	21	32.5	27	19	02046#05	G2AUE15L
	315	18	23.5	35.5	32	24	02046#06	G2AUE18L
	160	22	27.5	38.5	36	27	02046#07	G2AUE22L
	160	28	30.5	41.5	41	36	02046#08	G2AUE28L
	160	35	34.5	51	50	41	02046#09	G2AUE35L
	160	42	40	56	60	50	02046#10	G2AUE42L
S	400	6	16	27	17	12	02046#11	G2AUE06S
	400	8	17	27.5	19	14	02046#12	G2AUE08S
	400	10	17.5	30	22	17	02046#13	G2AUE10S
	400	12	21.5	31	24	17	02046#14	G2AUE12S
	400	14	22	35	27	19	02046#15	G2AUE14S
	400	16	24.5	36.5	30	24	02046#16	G2AUE16S
	400	20	26.5	44.5	36	27	02046#17	G2AUE20S
	400	25	30	50	46	36	02046#18	G2AUE25S
	400	30	35.5	55	50	41	02046#19	G2AUE30S

注:组合直角管接头可与各种端直通接头体组合使用,如下图:

NOTE: The Adjustable Union Elbow may be used for a combination of body of Male Connector, as below fig.:

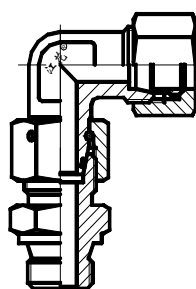

AUE与MCMA, MCGA

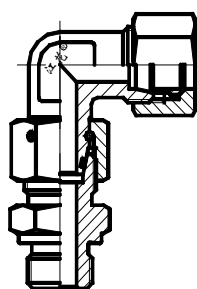

AUE与MCMB, MCGB

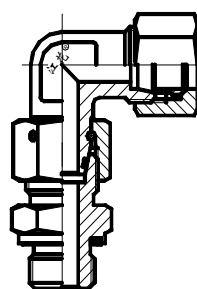

AUE与MCME, MCGE

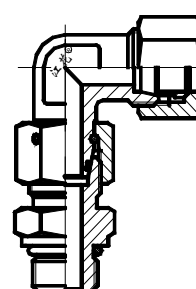

AUE与MCMF, MCFU



## G2SHEM

高压铰接式弯通管接头—公制螺纹

Swivel High-Pressure Elbow Union—Metric Thread

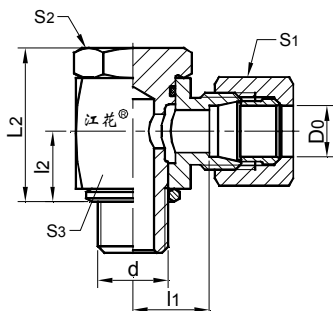

系列	PN	D0	d	l1	l2	L2	S1	S2	S3	产品编号	型号
Series	PN	D0	d	l1	l2	L2	S1	S2	S3	Product No	Type
L	250	6	M10×1	12	10.5	24	14	17	17	02047#01	G2SHEM06L
	250	8	M12×1.5	14.5	14	30	17	19	22	02047#02	G2SHEM08L
	250	10	M14×1.5	15.5	14	30	19	19	22	02047#03	G2SHEM10L
	250	12	M16×1.5	18	16.5	36	22	24	27	02047#04	G2SHEM12L
	250	15	M18×1.5	21.5	18.5	39.5	27	30	30	02047#05	G2SHEM15L
	250	18	M22×1.5	21	21.5	45	32	30	32	02047#06	G2SHEM18L
	160	22	M27×2	27.5	24	53	36	36	41	02047#07	G2SHEM22L
	160	28	M33×2	32	30.5	66	41	46	50	02047#08	G2SHEM28L
	160	35	M42×2	36	35.5	76	50	55	60	02047#09	G2SHEM35L
	160	42	M48×2	40.5	40.5	87	60	60	70	02047#10	G2SHEM42L
S	315	6	M12×1.5	16.5	14	30	17	19	22	02047#11	G2SHEM06S
	315	8	M14×1.5	16.5	14	30	19	19	22	02047#12	G2SHEM08S
	315	10	M16×1.5	18.5	16.5	36	22	24	27	02047#13	G2SHEM10S
	315	12	M18×1.5	20	18.5	39.5	24	27	27	02047#14	G2SHEM12S
	315	14	M20×1.5	22.5	20	43.5	27	30	32	02047#15	G2SHEM14S
	315	16	M22×1.5	22	21.5	45	30	30	32	02047#16	G2SHEM16S
	160	20	M27×2	26.5	24	53	36	36	41	02047#17	G2SHEM20S
	160	25	M33×2	31.5	30.5	66	46	46	50	02047#18	G2SHEM25S
	160	30	M42×2	37	35.5	76	50	55	60	02047#19	G2SHEM30S

## G2SHEG

高压铰接式弯通管接头—BSPP(G)螺纹

Swivel High-Pressure Elbow Union—BSPP Thread (G)

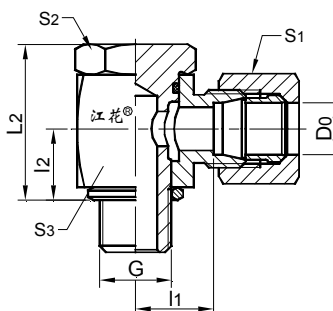

系列	PN	D0	d	l1	l2	L2	S1	S2	S3	产品编号	型号
Series	PN	D0	d	l1	l2	L2	S1	S2	S3	Product No	Type
L	250	6	G 1/8A	12	10.5	24	14	17	17	02048#01	G2SHEG06L
	250	8	G 1/4A	14.5	14	30	17	19	22	02048#02	G2SHEG08L
	250	10	G 1/4A	15.5	14	30	19	19	22	02048#03	G2SHEG10L
	250	12	G 3/8A	18	16.5	36	22	24	27	02048#04	G2SHEG12L
	250	15	G 1/2A	21.5	21.5	45	27	30	30	02048#05	G2SHEG15L
	250	18	G 1/2A	21	21.5	45	30	30	32	02048#06	G2SHEG18L
	160	22	G 3/4A	27.5	24	53	36	36	41	02048#07	G2SHEG22L
	160	28	G 1A	32	30.5	66	41	46	50	02048#08	G2SHEG28L
	160	35	G 1 1/4A	36	35.5	76	50	55	60	02048#09	G2SHEG35L
	160	42	G 1 1/2A	40.5	40.5	87	60	60	70	02048#10	G2SHEG42L
S	315	6	G 1/4A	16.5	14	30	17	19	22	02048#11	G2SHEG06S
	315	8	G 1/4A	16.5	14	30	19	19	22	02048#12	G2SHEG08S
	315	10	G 3/8A	18.5	16.5	36	22	24	27	02048#13	G2SHEG10S
	315	12	G 3/8A	20	18.5	39.5	24	27	27	02048#14	G2SHEG12S
	315	14	G 1/2A	22.5	20	43.5	27	30	32	02048#15	G2SHEG14S
	315	16	G 1/2A	22	21.5	45	30	30	32	02048#16	G2SHEG16S
	160	20	G 3/4A	26.5	24	53	36	36	41	02048#17	G2SHEG20S
	160	25	G 1A	31.5	30.5	66	41	46	50	02048#18	G2SHEG25S
	160	30	G 1 1/4A	37	35.5	76	50	55	60	02048#19	G2SHEG30S

**G2SHEME**

高压铰接式弯通管接头—公制螺纹弹性密封

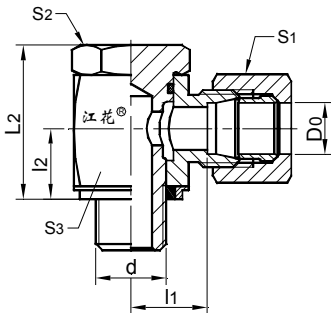
**Swivel High-Pressure Elbow Union**—Metric Thread with elastomer seal

系列	PN	D0	d	l1	l2	L2	S1	S2	S3	产品编号	型号
Series	PN	D0	d	l1	l2	L2	S1	S2	S3	Product No	Type
L	315	6	M10×1	12	10.5	24	14	17	17	02049#01	G2SHEME06L
	315	8	M12×1.5	14.5	14	30	17	19	22	02049#02	G2SHEME08L
	315	10	M14×1.5	15.5	14	30	19	19	22	02049#03	G2SHEME10L
	315	12	M16×1.5	18	16.5	36	22	24	27	02049#04	G2SHEME12L
	315	15	M18×1.5	21.5	18.5	39.5	27	30	30	02049#05	G2SHEME15L
	315	18	M22×1.5	21	21.5	45	32	30	32	02049#06	G2SHEME18L
	160	22	M27×2	27.5	24	53	36	36	41	02049#07	G2SHEME22L
	160	28	M33×2	32	30.5	66	41	46	50	02049#08	G2SHEME28L
	160	35	M42×2	36	35.5	76	50	55	60	02049#09	G2SHEME35L
	160	42	M48×2	40.5	40.5	87	60	60	70	02049#10	G2SHEME42L
S	400	6	M12×1.5	16.5	14	30	17	19	22	02049#11	G2SHEME06S
	400	8	M14×1.5	16.5	14	30	19	19	22	02049#12	G2SHEME08S
	400	10	M16×1.5	18.5	16.5	36	22	24	27	02049#13	G2SHEME10S
	400	12	M18×1.5	20	18.5	39.5	24	27	27	02049#14	G2SHEME12S
	315	14	M20×1.5	22.5	20	43.5	27	30	32	02049#15	G2SHEME14S
	315	16	M22×1.5	22	21.5	45	30	30	32	02049#16	G2SHEME16S
	315	20	M27×2	26.5	24	53	36	36	41	02049#17	G2SHEME20S
	250	25	M33×2	31.5	30.5	66	46	46	50	02049#18	G2SHEME25S
	160	30	M42×2	37	35.5	76	50	55	60	02049#19	G2SHEME30S

**G2SHEGE**

高压铰接式弯通管接头—BSPP(G)螺纹弹性密封

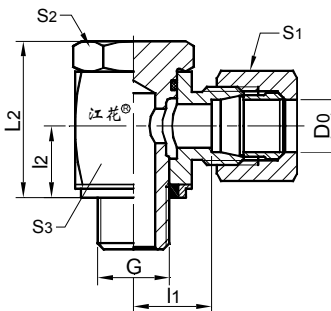
**Swivel High-Pressure Elbow Union**—BSPP Thread with elastomer seal

系列	PN	D0	d	l1	l2	L2	S1	S2	S3	产品编号	型号
Series	PN	D0	d	l1	l2	L2	S1	S2	S3	Product No	Type
L	315	6	G 1/8A	12	10.5	24	14	17	17	02050#01	G2SHEGE06L
	315	8	G 1/4A	14.5	14	30	17	19	22	02050#02	G2SHEGE08L
	315	10	G 1/4A	15.5	14	30	19	19	22	02050#03	G2SHEGE10L
	315	12	G 3/8A	18	16.5	36	22	24	27	02050#04	G2SHEGE12L
	315	15	G 1/2A	21.5	21.5	45	27	30	30	02050#05	G2SHEGE15L
	315	18	G 1/2A	21	21.5	45	30	30	32	02050#06	G2SHEGE18L
	160	22	G 3/4A	27.5	24	53	36	36	41	02050#07	G2SHEGE22L
	160	28	G 1A	32	30.5	66	41	46	50	02050#08	G2SHEGE28L
	160	35	G 1 1/4A	36	35.5	76	50	55	60	02050#09	G2SHEGE35L
	160	42	G 1 1/2A	40.5	40.5	87	60	60	70	02050#10	G2SHEGE42L
S	400	6	G 1/4A	16.5	14	30	17	19	22	02050#11	G2SHEGE06S
	400	8	G 1/4A	16.5	14	30	19	19	22	02050#12	G2SHEGE08S
	400	10	G 3/8A	18.5	16.5	36	22	24	27	02050#13	G2SHEGE10S
	400	12	G 3/8A	20	18.5	39.5	24	27	27	02050#14	G2SHEGE12S
	315	14	G 1/2A	22.5	20	43.5	27	30	32	02050#15	G2SHEGE14S
	315	16	G 1/2A	22	21.5	45	30	30	32	02050#16	G2SHEGE16S
	315	20	G 3/4A	26.5	24	53	36	36	41	02050#17	G2SHEGE20S
	250	25	G 1A	31.5	30.5	66	41	46	50	02050#18	G2SHEGE25S
	160	30	G 1 1/4A	37	35.5	76	50	55	60	02050#19	G2SHEGE30S

**G2BWE**  
焊接弯通管接头  
Butt-welding Elbow

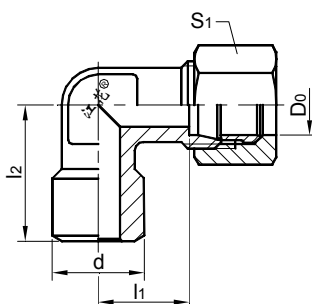

系列 Series	PN	D0	l1	l2	d	S1	产品编号 Product No	型号 Type
L	250	6	12	19	10	14	02051#01	G2BWE06L
	250	8	14	23	12	17	02051#02	G2BWE08L
	250	10	15	24	14	19	02051#03	G2BWE10L
	250	12	17	25	16	22	02051#04	G2BWE12L
	250	15	21	30	19	27	02051#05	G2BWE15L
	250	18	23.5	33	22	32	02051#06	G2BWE18L
	160	22	27.5	37	27	36	02051#07	G2BWE22L
	160	28	30.5	42	32	41	02051#08	G2BWE28L
	160	35	34.5	49	40	50	02051#09	G2BWE35L
	160	42	40	57	46	60	02051#10	G2BWE42L
S	400	6	16	23	11	17	02051#11	G2BWE06S
	400	8	17	24	13	19	02051#12	G2BWE08S
	400	10	17.5	25	15	22	02051#13	G2BWE10S
	400	12	21.5	29	17	24	02051#14	G2BWE12S
	400	14	22	30	19	27	02051#15	G2BWE14S
	400	16	24.5	33	21	30	02051#16	G2BWE16S
	400	20	26.5	37	26	36	02051#17	G2BWE20S
	400	25	30	42	31	46	02051#18	G2BWE25S
	400	30	35.5	49	36	50	02051#19	G2BWE30S

**G2T**  
三通管接头  
Union Tee

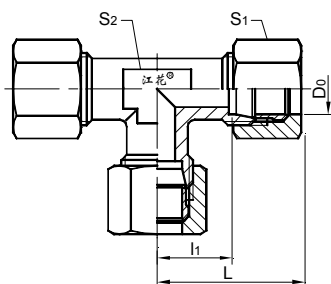

系列 Series	PN	D0	l1	L	S1	S2	产品编号 Product No	型号 Type
L	315	6	12	29	14	12	02052#01	G2T06L
	315	8	14	31.5	17	14	02052#02	G2T08L
	315	10	15	34	19	17	02052#03	G2T10L
	315	12	17	36.5	22	19	02052#04	G2T12L
	315	15	21	41	27	19	02052#05	G2T15L
	315	18	23.5	44	32	24	02052#06	G2T18L
	160	22	27.5	51	36	27	02052#07	G2T22L
	160	28	30.5	54.5	41	36	02052#08	G2T28L
	160	35	34.5	61	50	41	02052#09	G2T35L
	160	42	40	67.5	60	50	02052#10	G2T42L
S	400	6	16	33.5	17	12	02052#11	G2T06S
	400	8	17	35.5	19	14	02052#12	G2T08S
	400	10	17.5	37.5	22	17	02052#13	G2T10S
	400	12	21.5	41.5	24	17	02052#14	G2T12S
	400	14	22	43.5	27	19	02052#15	G2T14S
	400	16	24.5	46.5	30	24	02052#16	G2T16S
	400	20	26.5	52	36	27	02052#17	G2T20S
	400	25	30	58	46	36	02052#18	G2T25S
	400	30	35.5	67.5	50	41	02052#19	G2T30S

## G2MBTMA

端分支三通管接头—公制螺纹垫片密封(型式A)

Male Branch Tee—Metric Thread with Gasket Seal Type A

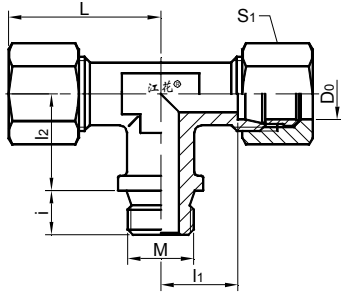

系列	PN	D0	M	i	I1	L	I2	S1	产品编号	型号
Series	PN	D0	M	i	I1	L	I2	S1	Product No	Type
L	250	6	M10×1	8	12	29	14	14	02053#01	G2MBTMA06L
	250	8	M12×1.5	12	14	31.5	16	17	02053#02	G2MBTMA08L
	250	10	M14×1.5	12	15	34	17	19	02053#03	G2MBTMA10L
	250	12	M16×1.5	12	17	36.5	19	22	02053#04	G2MBTMA12L
	250	15	M22×1.5	14	21	41	22	27	02053#05	G2MBTMA15L
	250	18	M22×1.5	14	23.5	44	24	32	02053#06	G2MBTMA18L
	160	22	M27×2	16	27.5	51	27	36	02053#07	G2MBTMA22L
	160	28	M33×2	18	30.5	54.5	30	41	02053#08	G2MBTMA28L
	160	35	M42×2	20	34.5	61	35	50	02053#09	G2MBTMA35L
	160	42	M48×2	22	40	67.5	41	60	02053#10	G2MBTMA42L
S	400	6	M12×1.5	12	16	33.5	16	17	02053#11	G2MBTMA06S
	400	8	M14×1.5	12	17	35.5	17	19	02053#12	G2MBTMA08S
	400	10	M16×1.5	12	17.5	37.5	19	22	02053#13	G2MBTMA10S
	400	12	M18×1.5	12	21.5	41.5	19	24	02053#14	G2MBTMA12S
	400	14	M18×1.5	14	22	43.5	22	27	02053#15	G2MBTMA14S
	400	16	M22×1.5	14	24.5	46.5	23	30	02053#16	G2MBTMA16S
	400	20	M27×2	16	26.5	52	27	36	02053#17	G2MBTMA20S
	400	25	M33×2	18	30	58	31	46	02053#18	G2MBTMA25S
	400	30	M42×2	20	35.5	67.5	34	50	02053#19	G2MBTMA30S

## G2MBTGA

端分支三通管接头—英制管螺纹(BSP)垫片密封(型式A)

Male Branch Tee—Whitworth BSP Thread with Gasket Seal Type A

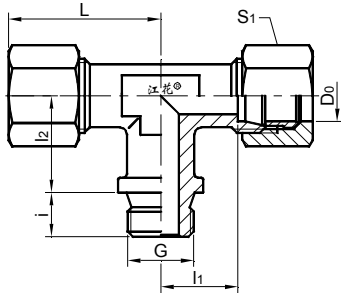

系列	PN	D0	G	i	I1	L	I2	S1	产品编号	型号
Series	PN	D0	G	i	I1	L	I2	S1	Product No	Type
L	250	6	G1/8A	8	12	29	14	14	02054#01	G2MBTGA06L
	250	8	G1/4A	12	14	31.5	16	17	02054#02	G2MBTGA08L
	250	10	G1/4A	12	15	34	17	19	02054#03	G2MBTGA10L
	250	12	G3/8A	12	17	36.5	19	22	02054#04	G2MBTGA12L
	250	15	G1/2A	14	21	41	22	27	02054#05	G2MBTGA15L
	250	18	G1/2A	14	23.5	44	24	32	02054#06	G2MBTGA18L
	160	22	G3/4A	16	27.5	51	27	36	02054#07	G2MBTGA22L
	160	28	G1A	18	30.5	54.5	30	41	02054#08	G2MBTGA28L
	160	35	G11/4A	20	34.5	61	35	50	02054#09	G2MBTGA35L
	160	42	G11/2A	22	40	67.5	41	60	02054#10	G2MBTGA42L
S	400	6	G1/4A	12	16	33.5	16	17	02054#11	G2MBTGA06S
	400	8	G1/4A	12	17	35.5	17	19	02054#12	G2MBTGA08S
	400	10	G3/8A	12	17.5	37.5	19	22	02054#13	G2MBTGA10S
	400	12	G3/8A	12	21.5	41.5	19	24	02054#14	G2MBTGA12S
	400	14	G1/2A	14	22	43.5	22	27	02054#15	G2MBTGA14S
	400	16	G1/2A	14	24.5	46.5	23	30	02054#16	G2MBTGA16S
	400	20	G3/4A	16	26.5	52	27	36	02054#17	G2MBTGA20S
	400	25	G1A	18	30	58	31	46	02054#18	G2MBTGA25S
	400	30	G11/4A	20	35.5	67.5	34	50	02054#19	G2MBTGA30S

注: 米制螺纹M终端和BSP圆柱管螺纹终端(型式A)常规采用组合垫片密封,金属平垫也可适用。

NOTE: Metric thread ends M and BSP parallel thread ends (Form A) are typically used with a gasket having a bonded elastomer seal. The flat metal gaskets may also be used.

## G2MRTMA

端直路三通管接头—公制螺纹垫片密封 (型式A)

Male Run Tee—Metric Thread with Gasket Seal Type A

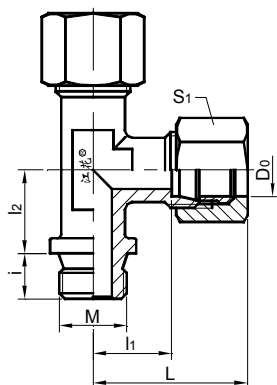

系列	PN	D0	M	i	l1	L	l2	S1	产品编号	型号
Series	PN	D0	M	i	l1	L	l2	S1	Product No.	Type
L	315	6	M10×1	8	12	29	14	14	02055#01	G2MRTMA06L
	315	8	M12×1.5	12	14	31.5	16	17	02055#02	G2MRTMA08L
	315	10	M14×1.5	12	15	34	17	19	02055#03	G2MRTMA10L
	315	12	M16×1.5	12	17	36.5	19	22	02055#04	G2MRTMA12L
	315	15	M22×1.5	14	21	41	22	27	02055#05	G2MRTMA15L
	315	18	M22×1.5	14	23.5	44	24	32	02055#06	G2MRTMA18L
	160	22	M27×2	16	27.5	51	27	36	02055#07	G2MRTMA22L
	160	28	M33×2	18	30.5	54.5	30	41	02055#08	G2MRTMA28L
	160	35	M42×2	20	34.5	61	35	50	02055#09	G2MRTMA35L
	160	42	M48×2	22	40	67.5	41	60	02055#10	G2MRTMA42L
S	400	6	M12×1.5	12	16	33.5	16	17	02055#11	G2MRTMA06S
	400	8	M14×1.5	12	17	35.5	17	19	02055#12	G2MRTMA08S
	400	10	M16×1.5	12	17.5	37.5	19	22	02055#13	G2MRTMA10S
	400	12	M18×1.5	12	21.5	41.5	19	24	02055#14	G2MRTMA12S
	400	14	M18×1.5	14	22	43.5	22	27	02055#15	G2MRTMA14S
	400	16	M22×1.5	14	24.5	46.5	23	30	02055#16	G2MRTMA16S
	400	20	M27×2	16	26.5	52	27	36	02055#17	G2MRTMA20S
	400	25	M33×2	18	30	58	31	46	02055#18	G2MRTMA25S
	400	30	M42×2	20	35.5	67.5	34	50	02055#19	G2MRTMA30S

## G2MRTGA

端直路三通管接头—英制管螺纹 (BSPP) 垫片密封 (型式A)

Male Run Tee—Whitworth BSPP Thread with Gasket Seal Type A

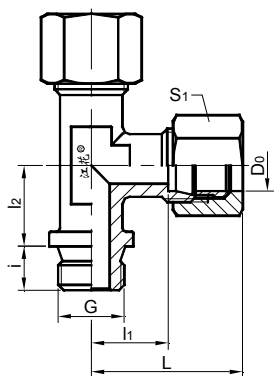

系列	PN	D0	G	i	l1	L	l2	S1	产品编号	型号
Series	PN	D0	G	i	l1	L	l2	S1	Product No.	Type
L	250	6	G1/8A	8	12	29	14	14	02056#01	G2MRTGA06L
	250	8	G1/4A	12	14	31.5	16	17	02056#02	G2MRTGA08L
	250	10	G1/4A	12	15	34	17	19	02056#03	G2MRTGA10L
	250	12	G3/8A	12	17	36.5	19	22	02056#04	G2MRTGA12L
	250	15	G1/2A	14	21	41	22	27	02056#05	G2MRTGA15L
	250	18	G1/2A	14	23.5	44	24	32	02056#06	G2MRTGA18L
	160	22	G3/4A	16	27.5	51	27	36	02056#07	G2MRTGA22L
	160	28	G1A	18	30.5	54.5	30	41	02056#08	G2MRTGA28L
	160	35	G11/4A	20	34.5	61	35	50	02056#09	G2MRTGA35L
	160	42	G11/2A	22	40	67.5	41	60	02056#10	G2MRTGA42L
S	400	6	G1/4A	12	16	33.5	16	17	02056#11	G2MRTGA06S
	400	8	G1/4A	12	17	35.5	17	19	02056#12	G2MRTGA08S
	400	10	G3/8A	12	17.5	37.5	19	22	02056#13	G2MRTGA10S
	400	12	G3/8A	12	21.5	41.5	19	24	02056#14	G2MRTGA12S
	400	14	G1/2A	14	22	43.5	22	27	02056#15	G2MRTGA14S
	400	16	G1/2A	14	24.5	46.5	23	30	02056#16	G2MRTGA16S
	400	20	G3/4A	16	26.5	52	27	36	02056#17	G2MRTGA20S
	400	25	G1A	18	30	58	31	46	02056#18	G2MRTGA25S
	400	30	G11/4A	20	35.5	67.5	34	50	02056#19	G2MRTGA30S

注: 米制螺纹M终端和BSP圆柱管螺纹终端 (型式A) 常规采用组合垫片密封, 金属平垫也可适用。

NOTE: Metric thread ends M and BSPP parallel thread ends (Form A) are typically used with a gasket having a bonded elastomer seal. The flat metal gaskets may also be used.

## G2MBTN

端分支三通管接头—NPT螺纹

Male Branch Tee—NPT Thread

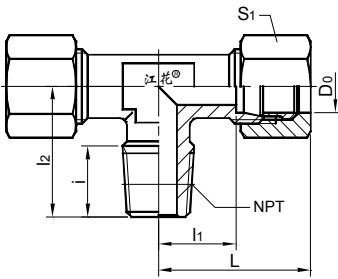

系列	PN	D0	NPT	i	l1	l2	S1	产品编号	型号
Series	PN	D0	NPT	i	l1	l2	S1	Product No	Type
L	315	6	1/8NPT	10	12	20	14	02057#01	G2MBTN06L/1/8NPT
	315	8	1/4NPT	14.5	14	26	17	02057#02	G2MBTN08L/1/4NPT
	315	10	1/4NPT	14.5	15	27	19	02057#03	G2MBTN10L/1/4NPT
	315	12	3/8NPT	15	17	28	22	02057#04	G2MBTN12L/3/8NPT
	315	15	1/2NPT	19	21	34	27	02057#05	G2MBTN15L/1/2NPT
	315	18	1/2NPT	19	23.5	36	32	02057#06	G2MBTN18L/1/2NPT
	160	22	3/4NPT	19	27.5	42	36	02057#07	G2MBTN22/3/4NPT
	160	28	1NPT	24	30.5	48	41	02057#08	G2MBTN28L/1NPT
	160	35	1 1/4NPT	25	34.5	54	50	02057#09	G2MBTN35L/1 1/4NPT
	160	42	1 1/2NPT	26	40	61	60	02057#10	G2MBTN42L/1 1/2NPT
S	400	6	1/4NPT	14.5	16	26	17	02057#11	G2MBTN06S/1/4NPT
	400	8	1/4NPT	14.5	17	27	19	02057#12	G2MBTN08S/1/4NPT
	400	10	3/8NPT	15	17.5	28	22	02057#13	G2MBTN10S/3/8NPT
	400	12	3/8NPT	15	22.5	28	24	02057#14	G2MBTN12S/3/8NPT
	400	14	1/2NPT	19	22	34	27	02057#15	G2MBTN14S/1/2NPT
	400	16	1/2NPT	19	24.5	36	30	02057#16	G2MBTN16S/1/2NPT
	400	20	3/4NPT	19	26.5	42	36	02057#17	G2MBTN20S/3/4NPT
	400	25	1NPT	24	30	48	46	02057#18	G2MBTN25S/1NPT
	250	30	1 1/4NPT	25	35.5	54	50	02057#19	G2MBTN30S/1 1/4NPT

## G2MRTN

端直路三通管接头—NPT螺纹

Male Run Tee—NPT Thread

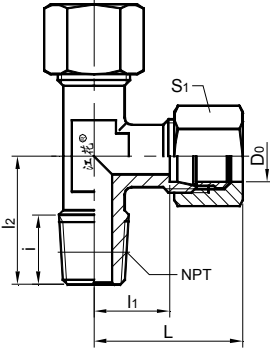

系列	PN	D0	NPT	i	l1	l2	S1	产品编号	型号
Series	PN	D0	NPT	i	l1	l2	S1	Product No	Type
L	315	6	1/8NPT	10	12	20	14	02058#01	G2MRTN06L/1/8NPT
	315	8	1/4NPT	14.5	14	26	17	02058#02	G2MRTN08L/1/4NPT
	315	10	1/4NPT	14.5	15	27	19	02058#03	G2MRTN10L/1/4NPT
	315	12	3/8NPT	15	17	28	22	02058#04	G2MRTN12L/3/8NPT
	315	15	1/2NPT	19	21	34	27	02058#05	G2MRTN15L/1/2NPT
	315	18	1/2NPT	19	23.5	36	32	02058#06	G2MRTN18L/1/2NPT
	160	22	3/4NPT	19	27.5	42	36	02058#07	G2MRTN22/3/4NPT
	160	28	1NPT	24	30.5	48	41	02058#08	G2MRTN28L/1NPT
	160	35	1 1/4NPT	25	34.5	54	50	02058#09	G2MRTN35L/1 1/4NPT
	160	42	1 1/2NPT	26	40	61	60	02058#10	G2MRTN42L/1 1/2NPT
S	400	6	1/4NPT	14.5	16	26	17	02058#11	G2MRTN06S/1/4NPT
	400	8	1/4NPT	14.5	17	27	19	02058#12	G2MRTN08S/1/4NPT
	400	10	3/8NPT	15	17.5	28	22	02058#13	G2MRTN10S/3/8NPT
	400	12	3/8NPT	15	22.5	28	24	02058#14	G2MRTN12S/3/8NPT
	400	14	1/2NPT	19	22	34	27	02058#15	G2MRTN14S/1/2NPT
	400	16	1/2NPT	19	24.5	36	30	02058#16	G2MRTN16S/1/2NPT
	400	20	3/4NPT	19	26.5	42	36	02058#17	G2MRTN20S/3/4NPT
	400	25	1NPT	24	30	48	46	02058#18	G2MRTN25S/1NPT
	250	30	1 1/4NPT	25	35.5	54	50	02058#19	G2MRTN30S/1 1/4NPT

**G2AMBTMF**

可调向端分支三通管接头—公制螺纹O型圈密封(ISO 6149-1 型式F)

**Adjustable Male Branch Tee**

—Metric Thread with O-ring Seal Type F (ISO 6149-1 Ports)

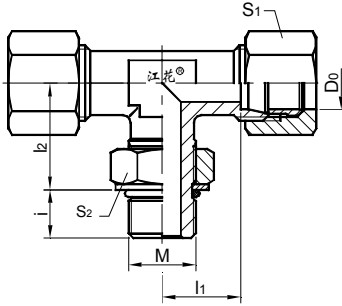

系列	PN	D0	M	I1	I2	S1	S2	产品编号	型号
Series	PN	D0	M	I1	I2	S1	S2	Product No	Type
L	315	6	M10×1	14	20	14	14	02059#01	G2AMBTMF06L
	315	8	M12×1.5	16	22	17	17	02059#02	G2AMBTMF08L
	315	10	M14×1.5	17	25	19	19	02059#03	G2AMBTMF10L
	315	12	M16×1.5	19	26	22	22	02059#04	G2AMBTMF12L
	315	15	M18×1.5	21	30	27	24	02059#05	G2AMBTMF15L
	250	18	M22×1.5	24	33	32	27	02059#06	G2AMBTMF18L
	160	22	M27×2	28	35	36	32	02059#07	G2AMBTMF22L
	160	28	M33×2	31	38	41	41	02059#08	G2AMBTMF28L
	160	35	M42×2	38	48	50	50	02059#09	G2AMBTMF35L
	160	42	M48×2	38	49	60	55	02059#10	G2AMBTMF42L
S	315	6	M12×1.5	15	22	17	17	02059#11	G2AMBTMF06S
	315	8	M14×1.5	17	26	19	19	02059#12	G2AMBTMF08S
	315	10	M16×1.5	18	27	22	22	02059#13	G2AMBTMF10S
	315	12	M18×1.5	22	31	24	24	02059#14	G2AMBTMF12S
	250	16	M22×1.5	25	35	30	27	02059#15	G2AMBTMF16S
	250	20	M27×2	28	39	36	32	02059#16	G2AMBTMF20S
	160	25	M33×2	30	44	46	41	02059#17	G2AMBTMF25S
	160	30	M42×2	36	51	50	50	02059#18	G2AMBTMF30S

**G2AMBTUF**

可调向端分支三通管接头—UN/UNF螺纹O型圈密封(SAE J1926-1 型式F)

**Adjustable Male Branch Tee**

—UN/UNF Thread with O-ring Seal Type F (SAE J1926-1 Ports)

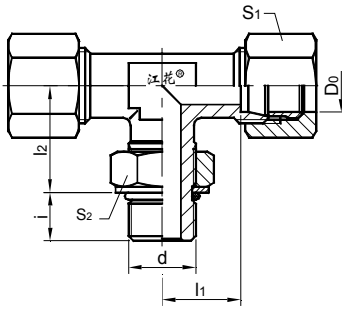

系列	PN	D0	d	I1	I2	S1	S2	产品编号	型号
Series	PN	D0	d	I1	I2	S1	S2	Product No	Type
L	315	6	7/16-20UNF	14	19	14	14	02060#01	G2AMBTUF06L
	315	8	7/16-20UNF	16	19	17	14	02060#02	G2AMBTUF08L
	315	10	9/16-18UNF	17	24	19	17	02060#03	G2AMBTUF10L
	315	12	9/16-18UNF	19	25	22	17	02060#04	G2AMBTUF12L
	315	12	3/4-16UNF	19	25	22	22	02060#05	G2AMBTUF12L-3/4UNF
	315	15	3/4-16UNF	21	28	27	22	02060#06	G2AMBTUF15L
	315	15	7/8-14UNF	21	28	27	27	02060#07	G2AMBTUF15L-7/8UNF
	315	18	7/8-14UNF	24	32	32	27	02060#08	G2AMBTUF18L
	315	18	1 1/16-12UN	24	32	32	32	02060#09	G2AMBTUF18L-1 1/16UN
	160	22	1 1/16-12UN	28	35	36	32	02060#10	G2AMBTUF22L
	160	28	1 5/16-12UN	31	42	41	41	02060#11	G2AMBTUF28L
	160	35	1 5/8-12UN	38	46	50	50	02060#12	G2AMBTUF35L
	160	42	1 7/8-12UN	38	47	60	55	02060#13	G2AMBTUF42L
S	400	6	7/16-20UNF	15	20	17	17	02060#14	G2AMBTUF06S
	400	8	9/16-18UNF	17	25	19	19	02060#15	G2AMBTUF08S
	400	10	9/16-18UNF	18	26	22	22	02060#16	G2AMBTUF10S
	400	12	3/4-16UNF	22	30	24	24	02060#17	G2AMBTUF12S
	400	16	7/8-14UNF	25	34	30	27	02060#18	G2AMBTUF16S
	400	20	1 1/16-12UN	28	37	36	32	02060#19	G2AMBTUF20S
	400	25	1 1/16-12UN	30	50	46	41	02060#20	G2AMBTUF25S
	250	30	1 5/8-12UN	36	50	50	50	02060#21	G2AMBTUF30S

**G2AMBTMH**

可调向端分支三通管接头—公制螺纹O型圈带支承环密封(型式H)

**Adjustable Male Branch Tee**

—Metric Thread with O-ring and Retaining Ring Seal Type H

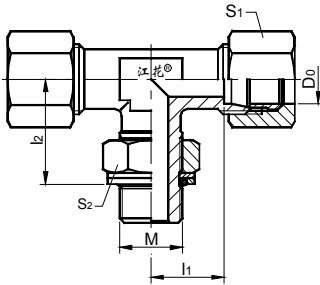

系列 Series	PN	D0	M	I1	I2	S1	S2	产品编号 Product No	型号 Type
L	315	6	M10×1	14	20	14	14	02061#01	G2AMBTMH06L
	315	8	M12×1.5	16	22	17	17	02061#02	G2AMBTMH08L
	315	10	M14×1.5	17	24	19	19	02061#03	G2AMBTMH10L
	315	12	M16×1.5	19	25	22	22	02061#04	G2AMBTMH12L
	315	15	M18×1.5	21	31	27	24	02061#05	G2AMBTMH15L
	250	18	M22×1.5	24	33	32	27	02061#06	G2AMBTMH18L
	160	22	M27×2	28	36	36	32	02061#07	G2AMBTMH22L
	160	28	M33×2	31	39	41	41	02061#08	G2AMBTMH28L
	160	35	M42×2	38	49	50	50	02061#09	G2AMBTMH35L
	160	42	M48×2	38	50	60	55	02061#10	G2AMBTMH42L
S	315	6	M12×1.5	15	22	17	17	02061#11	G2AMBTMH06S
	315	8	M14×1.5	17	26	19	19	02061#12	G2AMBTMH08S
	315	10	M16×1.5	18	27	22	22	02061#13	G2AMBTMH10S
	315	12	M18×1.5	22	31	24	24	02061#14	G2AMBTMH12S
	250	16	M22×1.5	25	36	30	27	02061#15	G2AMBTMH16S
	250	20	M27×2	28	39	36	32	02061#16	G2AMBTMH20S
	160	25	M33×2	30	44	46	41	02061#17	G2AMBTMH25S
	160	30	M42×2	36	51	50	50	02061#18	G2AMBTMH30S

**G2AMBTGH**

可调向端分支三通管接头—BSPP螺纹O型圈带支承环密封(ISO 1179-1 型式H)

**Adjustable Male Branch Tee**

—BSPP Thread with O-ring and Retaining Ring Seal Type H (ISO 1179-1 Ports)

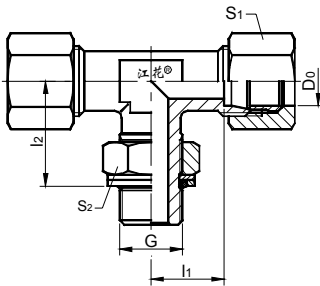

系列 Series	PN	D0	G	I1	I2	S1	S2	产品编号 Product No	型号 Type
L	315	6	G1/8A	14	19	14	14	02062#01	G2AMBTGH06L
	315	8	G1/4A	16	23	17	19	02062#02	G2AMBTGH08L
	315	10	G1/4A	17	25	19	19	02062#03	G2AMBTGH10L
	315	12	G3/8A	19	28	22	22	02062#04	G2AMBTGH12L
	315	15	G1/2A	21	30	27	27	02062#05	G2AMBTGH15L
	250	18	G1/2A	24	36	32	27	02062#06	G2AMBTGH18L
	160	22	G3/4A	28	36	36	36	02062#07	G2AMBTGH22L
	160	28	G1A	31	44	41	41	02062#08	G2AMBTGH28L
	160	35	G1 1/4A	38	50	50	50	02062#09	G2AMBTGH35L
	160	42	G1 1/2A	38	52	60	55	02062#10	G2AMBTGH42L
S	315	6	G1/4A	15	23	17	19	02062#11	G2AMBTGH06S
	315	8	G1/4A	17	27	19	19	02062#12	G2AMBTGH08S
	315	10	G3/8A	18	29	22	22	02062#13	G2AMBTGH10S
	315	12	G3/8A	22	29	24	2	02062#14	G2AMBTGH12S
	250	16	G1/2A	25	36	30	27	02062#15	G2AMBTGH16S
	250	20	G3/4A	28	39	36	36	02062#16	G2AMBTGH20S
	160	25	G1A	30	44	46	41	02062#17	G2AMBTGH25S
	160	30	G1 1/4A	36	49	50	50	02062#18	G2AMBTGH30S



**G2AMRTMF**

可调向端直路三通管接头—公制螺纹O型圈密封(ISO 6149-1 型式F)

**Adjustable Male Run Tee**

—Metric Thread with O-ring Seal Type F (ISO 6149-1 Ports)

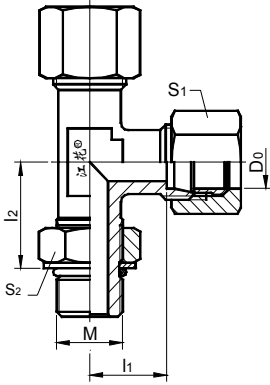

系列	产品编号							型号	
Series	PN	D0	M	I1	I2	S1	S2	Product No	Type
L	315	6	M10×1	14	20	14	14	02063#01	G2AMBTMF06L
	315	8	M12×1.5	16	22	17	17	02063#02	G2AMBTMF08L
	315	10	M14×1.5	17	25	19	19	02063#03	G2AMBTMF10L
	315	12	M16×1.5	19	26	22	22	02063#04	G2AMBTMF12L
	315	15	M18×1.5	21	30	27	24	02063#05	G2AMBTMF15L
	250	18	M22×1.5	24	33	32	27	02063#06	G2AMBTMF18L
	160	22	M27×2	28	35	36	32	02063#07	G2AMBTMF22L
	160	28	M33×2	31	38	41	41	02063#08	G2AMBTMF28L
	160	35	M42×2	38	48	50	50	02063#09	G2AMBTMF35L
	160	42	M48×2	38	49	60	55	02063#10	G2AMBTMF42L
S	315	6	M12×1.5	15	22	17	17	02063#11	G2AMBTMF06S
	315	8	M14×1.5	17	26	19	19	02063#12	G2AMBTMF08S
	315	10	M16×1.5	18	27	22	22	02063#13	G2AMBTMF10S
	315	12	M18×1.5	22	31	24	24	02063#14	G2AMBTMF12S
	250	16	M22×1.5	25	35	30	27	02063#15	G2AMBTMF16S
	250	20	M27×2	28	39	36	32	02063#16	G2AMBTMF20S
	160	25	M33×2	30	44	46	41	02063#17	G2AMBTMF25S
	160	30	M42×2	36	51	50	50	02063#18	G2AMBTMF30S

**G2AMRTUF**

可调向端直路三通管接头—UN/UNF螺纹O型圈密封(SAE J1926-1 型式F)

**Adjustable Male Run Tee**

—UN/UNF Thread with O-ring Seal Type F (SAE J1926-1 Ports)

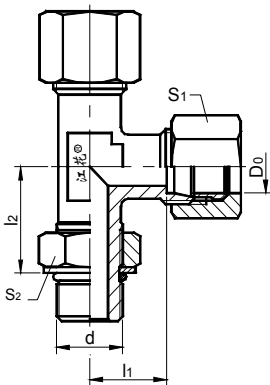

系列	产品编号							型号	
Series	PN	D0	d	I1	I2	S1	S2	Product No	Type
L	315	6	7/16-20UNF	14	19	14	14	02064#01	G2AMRTUF06L
	315	8	7/16-20UNF	16	19	17	14	02064#02	G2AMRTUF08L
	315	10	9/16-18UNF	17	24	19	17	02064#03	G2AMRTUF10L
	315	12	9/16-18UNF	19	25	22	17	02064#04	G2AMRTUF12L
	315	12	3/4-16UNF	19	25	22	22	02064#05	G2AMRTUF12L-3/4UNF
	315	15	3/4-16UNF	21	28	27	22	02064#06	G2AMRTUF15L
	315	15	7/8-14UNF	21	28	27	27	02064#07	G2AMRTUF15L-7/8UNF
	315	18	7/8-14UNF	24	32	32	27	02064#08	G2AMRTUF18L
	315	18	1 1/16-12UN	24	32	32	32	02064#09	G2AMRTUF18L-1 1/16UN
	160	22	1 1/16-12UN	28	35	36	32	02064#10	G2AMRTUF22L
	160	28	1 5/16-12UN	31	42	41	41	02064#11	G2AMRTUF28L
	160	35	1 5/8-12UN	38	46	50	50	02064#12	G2AMRTUF35L
	160	42	1 7/8-12UN	38	47	60	55	02064#13	G2AMRTUF42L
S	400	6	7/16-20UNF	15	20	17	17	02064#14	G2AMRTUF06S
	400	8	9/16-18UNF	17	25	19	19	02064#15	G2AMRTUF08S
	400	10	9/16-18UNF	18	26	22	22	02064#16	G2AMRTUF10S
	400	12	3/4-16UNF	22	30	24	24	02064#17	G2AMRTUF12S
	400	16	7/8-14UNF	25	34	30	27	02064#18	G2AMRTUF16S
	400	20	1 1/16-12UN	28	37	36	32	02064#19	G2AMRTUF20S
	400	25	1 1/16-12UN	30	50	46	41	02064#20	G2AMRTUF25S
	250	30	1 5/8-12UN	36	50	50	50	02064#21	G2AMRTUF30S

**G2AMRTMH**

可调向端直路三通管接头—公制螺纹O型圈带支承环密封(型式H)

**Adjustable Male Run Tee**

—Metric Thread with O-ring and Retaining Ring Seal Type H

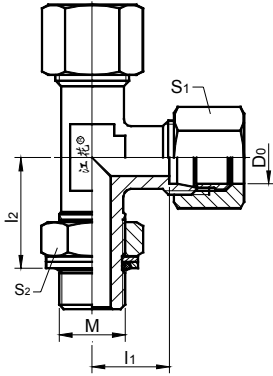

系列	产品编号	型号	
Series	PN	D0 M I1 I2 S1 S2	Product No Type
L	315 6	M10×1 14 20 14 14	02065#01 G2AMRTMH06L
	315 8	M12×1.5 16 22 17 17	02065#02 G2AMRTMH08L
	315 10	M14×1.5 17 24 19 19	02065#03 G2AMRTMH10L
	315 12	M16×1.5 19 25 22 22	02065#04 G2AMRTMH12L
	315 15	M18×1.5 21 31 27 24	02065#05 G2AMRTMH15L
	250 18	M22×1.5 24 33 32 27	02065#06 G2AMRTMH18L
	160 22	M27×2 28 36 36 32	02065#07 G2AMRTMH22L
	160 28	M33×2 31 39 41 41	02065#08 G2AMRTMH28L
	160 35	M42×2 38 49 50 50	02065#09 G2AMRTMH35L
	160 42	M48×2 38 50 60 55	02065#10 G2AMRTMH42L
S	315 6	M12×1.5 15 22 17 17	02065#11 G2AMRTMH06S
	315 8	M14×1.5 17 26 19 19	02065#12 G2AMRTMH08S
	315 10	M16×1.5 18 27 22 22	02065#13 G2AMRTMH10S
	315 12	M18×1.5 22 31 24 24	02065#14 G2AMRTMH12S
	250 16	M22×1.5 25 36 30 27	02065#15 G2AMRTMH16S
	250 20	M27×2 28 39 36 32	02065#16 G2AMRTMH20S
	160 25	M33×2 30 44 46 41	02065#17 G2AMRTMH25S
	160 30	M42×2 36 51 50 50	02065#18 G2AMRTMH30S

**G2AMRTGH**

可调向端直路三通管接头—BSPP螺纹O型圈带支承环密封(ISO 1179-1 型式H)

**Adjustable Male Run Tee**

—BSPP Thread with O-ring and Retaining Ring Seal Type H (ISO 1171-1 Ports)

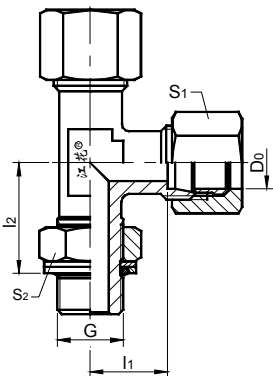

系列	产品编号	型号	
Series	PN	D0 G I1 I2 S1 S2	Product No Type
L	315 6	G1/8A 14 19 14 14	02066#01 G2AMRTGH06L
	315 8	G1/4A 16 23 17 19	02066#02 G2AMRTGH08L
	315 10	G1/4A 17 25 19 19	02066#03 G2AMRTGH10L
	315 12	G3/8A 19 28 22 22	02066#04 G2AMRTGH12L
	315 15	G1/2A 21 30 27 27	02066#05 G2AMRTGH15L
	250 18	G1/2A 24 36 32 27	02066#06 G2AMRTGH18L
	160 22	G3/4A 28 36 36 36	02066#07 G2AMRTGH22L
	160 28	G1A 31 44 41 41	02066#08 G2AMRTGH28L
	160 35	G1 1/4A 38 50 50 50	02066#09 G2AMRTGH35L
	160 42	G1 1/2A 38 52 60 55	02066#10 G2AMRTGH42L
S	315 6	G1/4A 15 23 17 19	02066#11 G2AMRTGH06S
	315 8	G1/4A 17 27 19 19	02066#12 G2AMRTGH08S
	315 10	G3/8A 18 29 22 22	02066#13 G2AMRTGH10S
	315 12	G3/8A 22 29 24 2	02066#14 G2AMRTGH12S
	250 16	G1/2A 25 36 30 27	02066#15 G2AMRTGH16S
	250 20	G3/4A 28 39 36 36	02066#16 G2AMRTGH20S
	160 25	G1A 30 44 46 41	02066#17 G2AMRTGH25S
	160 30	G1 1/4A 36 49 50 50	02066#18 G2AMRTGH30S

**G2ABT**  
组合分支三通管接头  
Adjustable Branch Tee

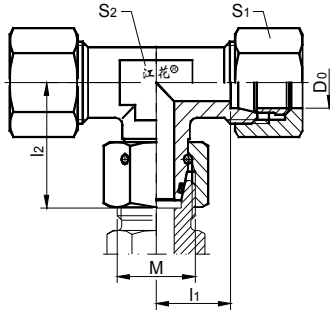

系列 Series	PN	D0	M	I1	I2	S1	S2	产品编号 Product No.	型号 Type
L	250	6	M12×1.5	13	26	14	10	02067#01	G2ABT06L
	250	8	M14×1.5	17.5	27.5	17	11	02067#02	G2ABT08L
	250	10	M16×1.5	18.5	29	19	15	02067#03	G2ABT10L
	250	12	M18×1.5	20	29.5	22	15	02067#04	G2ABT12L
	250	15	M22×1.5	23	32.5	27	21	02067#05	G2ABT15L
	250	18	M24×1.5	23	35.5	32	21	02067#06	G2ABT18L
	160	22	M30×2	28.5	38.5	36	27	02067#07	G2ABT22L
	160	28	M36×2	31	41.5	41	34	02067#08	G2ABT28L
	160	35	M45×2	36	51	50	46	02067#09	G2ABT35L
	160	42	M52×2	39.5	56	60	50	02067#10	G2ABT42L
S	400	6	M14×1.5	18	27	17	13	02067#11	G2ABT06S
	400	8	M16×1.5	19	27.5	19	15	02067#12	G2ABT08S
	400	10	M18×1.5	20	30	22	16	02067#13	G2ABT10S
	400	12	M20×1.5	21	31	24	18	02067#14	G2ABT12S
	400	14	M22×1.5	21	35	27	21	02067#15	G2ABT14S
	400	16	M24×1.5	23	36.5	30	21	02067#16	G2ABT16S
	400	20	M30×2	29	44.5	36	27	02067#17	G2ABT20S
	400	25	M36×2	31	50	46	34	02067#18	G2ABT25S
	400	30	M42×2	36	55	50	41	02067#19	G2ABT30S

注:组合分支三通管接头可与各种端直通接头体组合使用,如下图:

NOTE: The Adjustable Branch Tee may be used for a combination of body of Male Connectors, as below fig.:

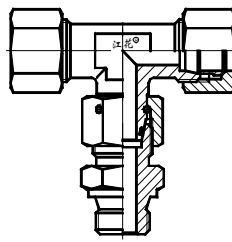

ABT与MCMA, MCGA

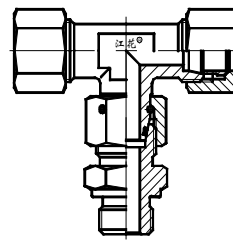

ABT与MCMB, MCGB

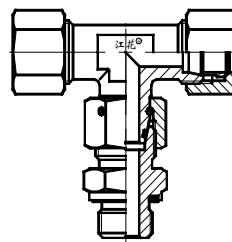

ABT与MCME, MCGE

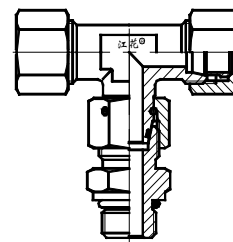

ABT与MCMF, MCUF

**G2ART**  
组合直路三通管接头  
Adjustable Run Tee

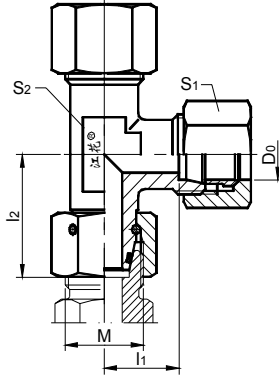

系列	PN	D0	M	l1	l2	S1	S2	产品编号	型号
Series	PN	D0	M	l1	l2	S1	S2	Product No	Type
L	250	6	M12×1.5	13	26	14	10	02068#01	G2ART06L
	250	8	M14×1.5	17.5	27.5	17	11	02068#02	G2ART08L
	250	10	M16×1.5	18.5	29	19	15	02068#03	G2ART10L
	250	12	M18×1.5	20	29.5	22	15	02068#04	G2ART12L
	250	15	M22×1.5	23	32.5	27	21	02068#05	G2ART15L
	250	18	M24×1.5	23	35.5	32	21	02068#06	G2ART18L
	160	22	M30×2	28.5	38.5	36	27	02068#07	G2ART22L
	160	28	M36×2	31	41.5	41	34	02068#08	G2ART28L
	160	35	M45×2	36	51	50	46	02068#09	G2ART35L
	160	42	M52×2	39.5	56	60	50	02068#10	G2ART42L
S	400	6	M14×1.5	18	27	17	13	02068#11	G2ART06S
	400	8	M16×1.5	19	27.5	19	15	02068#12	G2ART08S
	400	10	M18×1.5	20	30	22	16	02068#13	G2ART10S
	400	12	M20×1.5	21	31	24	18	02068#14	G2ART12S
	400	14	M22×1.5	21	35	27	21	02068#15	G2ART14S
	400	16	M24×1.5	23	36.5	30	21	02068#16	G2ART16S
	400	20	M30×2	29	44.5	36	27	02068#17	G2ART20S
	400	25	M36×2	31	50	46	34	02068#18	G2ART25S
	400	30	M42×2	36	55	50	41	02068#19	G2ART30S

注:组合直路三通管接头可与各种端直通接头体组合使用,如下图:

NOTE: The Adjustable Run Tee may be used for a combination of body of Male Connectors, as below fig.:

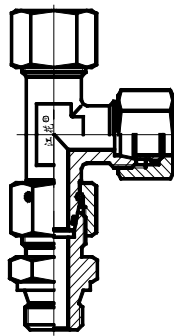

ART与MCMA, MCGA

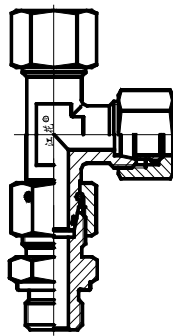

ART与MCMB, MCGB

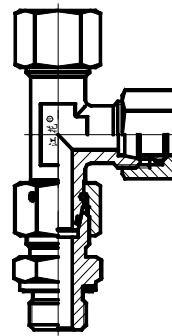

ART与MCME, MCGE

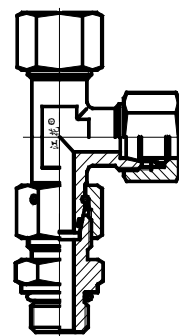

ART与MCMF, MCFU

### G2SHTM

高压铰接式三通管接头—公制螺纹

Swivel High-Pressure Tee Union—Metric Thread

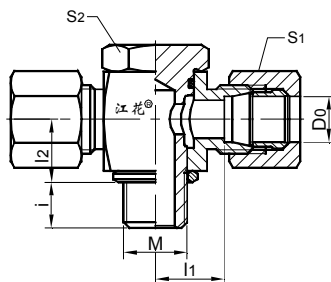

系列	PN	D0	M	i	l1	l2	S1	S2	产品编号	型号
Series	PN	D0	M	i	l1	l2	S1	S2	Product No	Type
L	250	6	M10×1	8	12	10.5	14	17	02069#01	G2SHTM06L
	250	8	M12×1.5	12	14.5	14	17	19	02069#02	G2SHTM08L
	250	10	M14×1.5	12	15.5	14	19	19	02069#03	G2SHTM10L
	250	12	M16×1.5	12	18	16.5	22	24	02069#04	G2SHTM12L
	250	15	M18×1.5	12	21.5	18.5	27	30	02069#05	G2SHTM15L
	250	18	M22×1.5	14	21	21.5	32	30	02069#06	G2SHTM18L
	160	22	M27×2	16	27.5	24	36	36	02069#07	G2SHTM22L
	160	28	M33×2	18	32	30.5	41	46	02069#08	G2SHTM28L
	160	35	M42×2	20	36	35.5	50	55	02069#09	G2SHTM35L
	160	42	M48×2	22	40.5	40.5	60	60	02069#10	G2SHTM42L
S	315	6	M12×1.5	12	16.5	14	17	19	02069#11	G2SHTM06S
	315	8	M14×1.5	12	16.5	14	19	19	02069#12	G2SHTM08S
	315	10	M16×1.5	12	18.5	16.5	22	24	02069#13	G2SHTM10S
	315	12	M18×1.5	12	20	18.5	24	27	02069#14	G2SHTM12S
	315	14	M20×1.5	14	22.5	20	27	30	02069#15	G2SHTM14S
	315	16	M22×1.5	14	22	21.5	30	30	02069#16	G2SHTM16S
	160	20	M27×2	16	26.5	24	36	36	02069#17	G2SHTM20S
	160	25	M33×2	18	31.5	30.5	46	46	02069#18	G2SHTM25S
	160	30	M42×2	20	37	35.5	50	55	02069#19	G2SHTM30S

### G2SHTG

高压铰接式弯通管接头—BSPP(G)螺纹

Swivel High-Pressure Tee Union—BSPP Thread (G)

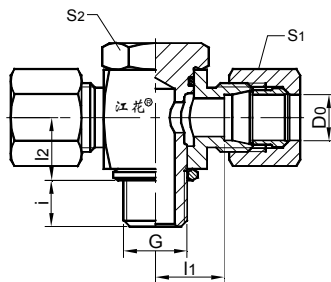

系列	PN	D0	G	i	l1	l2	S1	S2	产品编号	型号
Series	PN	D0	G	i	l1	l2	S1	S2	Product No	Type
L	250	6	G 1/8A	8	12	10.5	14	17	02070#01	G2SHTG06L
	250	8	G 1/4A	12	14.5	14	17	19	02070#02	G2SHTG08L
	250	10	G 1/4A	12	15.5	14	19	19	02070#03	G2SHTG10L
	250	12	G 3/8A	12	18	16.5	22	24	02070#04	G2SHTG12L
	250	15	G 1/2A	12	21.5	21.5	27	30	02070#05	G2SHTG15L
	250	18	G 1/2A	14	21	21.5	30	30	02070#06	G2SHTG18L
	160	22	G 3/4A	16	27.5	24	36	36	02070#07	G2SHTG22L
	160	28	G 1A	18	32	30.5	41	46	02070#08	G2SHTG28L
	160	35	G 1 1/4A	20	36	35.5	50	55	02070#09	G2SHTG35L
	160	42	G 1 1/2A	22	40.5	40.5	60	60	02070#10	G2SHTG42L
S	315	6	G 1/4A	12	16.5	14	17	19	02070#11	G2SHTG06S
	315	8	G 1/4A	12	16.5	14	19	19	02070#12	G2SHTG08S
	315	10	G 3/8A	12	18.5	16.5	22	24	02070#13	G2SHTG10S
	315	12	G 3/8A	12	20	18.5	24	27	02070#14	G2SHTG12S
	315	14	G 1/2A	14	22.5	20	27	30	02070#15	G2SHTG14S
	315	16	G 1/2A	14	22	21.5	30	30	02070#16	G2SHTG16S
	160	20	G 3/4A	16	26.5	24	36	36	02070#17	G2SHTG20S
	160	25	G 1A	18	31.5	30.5	41	46	02070#18	G2SHTG25S
	160	30	G 1 1/4A	20	37	35.5	50	55	02070#19	G2SHTG30S

## G2SHTME

高压铰接式三通管接头-公制螺纹弹性密封

Swivel High-Pressure Tee Union—Metric Thread with elastomer seal

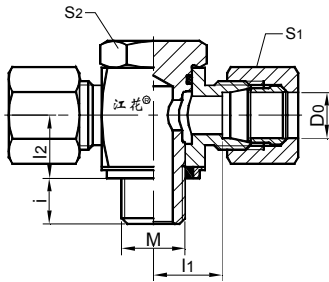

系列	PN	D0	M	i	l1	l2	S1	S2	产品编号	型号
Series	PN	D0	M	i	l1	l2	S1	S2	Product No	Type
L	315	6	M10×1	8	12	10.5	14	17	02071#01	G2SHTM06L
	315	8	M12×1.5	12	14.5	14	17	19	02071#02	G2SHTM08L
	315	10	M14×1.5	12	15.5	14	19	19	02071#03	G2SHTM10L
	315	12	M16×1.5	12	18	16.5	22	24	02071#04	G2SHTM12L
	315	15	M18×1.5	12	21.5	18.5	27	30	02071#05	G2SHTM15L
	315	18	M22×1.5	14	21	21.5	32	30	02071#06	G2SHTM18L
	160	22	M27×2	16	27.5	24	36	36	02071#07	G2SHTM22L
	160	28	M33×2	18	32	30.5	41	46	02071#08	G2SHTM28L
	160	35	M42×2	20	36	35.5	50	55	02071#09	G2SHTM35L
	160	42	M48×2	22	40.5	40.5	60	60	02071#10	G2SHTM42L
S	400	6	M12×1.5	12	16.5	14	17	19	02071#11	G2SHTM06S
	400	8	M14×1.5	12	16.5	14	19	19	02071#12	G2SHTM08S
	400	10	M16×1.5	12	18.5	16.5	22	24	02071#13	G2SHTM10S
	400	12	M18×1.5	12	20	18.5	24	27	02071#14	G2SHTM12S
	315	14	M20×1.5	14	22.5	20	27	30	02071#15	G2SHTM14S
	315	16	M22×1.5	14	22	21.5	30	30	02071#16	G2SHTM16S
	315	20	M27×2	16	26.5	24	36	36	02071#17	G2SHTM20S
	250	25	M33×2	18	31.5	30.5	46	46	02071#18	G2SHTM25S
	160	30	M42×2	20	37	35.5	50	55	02071#19	G2SHTM30S

## G2SHTGE

高压铰接式弯通管接头-BSPP(G)螺纹弹性密封

Swivel High-Pressure Tee Union—BSPP Thread with elastomer seal

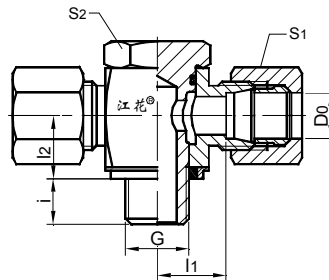

系列	PN	D0	G	i	l1	l2	S1	S2	产品编号	型号
Series	PN	D0	G	i	l1	l2	S1	S2	Product No	Type
L	315	6	G 1/8A	8	12	10.5	14	17	02072#01	G2SHTG06L
	315	8	G 1/4A	12	14.5	14	17	19	02072#02	G2SHTG08L
	315	10	G 1/4A	12	15.5	14	19	19	02072#03	G2SHTG10L
	315	12	G 3/8A	12	18	16.5	22	24	02072#04	G2SHTG12L
	315	15	G 1/2A	12	21.5	21.5	27	30	02072#05	G2SHTG15L
	315	18	G 1/2A	14	21	21.5	30	30	02072#06	G2SHTG18L
	160	22	G 3/4A	16	27.5	24	36	36	02072#07	G2SHTG22L
	160	28	G 1A	18	32	30.5	41	46	02072#08	G2SHTG28L
	160	35	G 1 1/4A	20	36	35.5	50	55	02072#09	G2SHTG35L
	160	42	G 1 1/2A	22	40.5	40.5	60	60	02072#10	G2SHTG42L
S	400	6	G 1/4A	12	16.5	14	17	19	02072#11	G2SHTG06S
	400	8	G 1/4A	12	16.5	14	19	19	02072#12	G2SHTG08S
	400	10	G 3/8A	12	18.5	16.5	22	24	02072#13	G2SHTG10S
	400	12	G 3/8A	12	20	18.5	24	27	02072#14	G2SHTG12S
	315	14	G 1/2A	14	22.5	20	27	30	02072#15	G2SHTG14S
	315	16	G 1/2A	14	22	21.5	30	30	02072#16	G2SHTG16S
	315	20	G 3/4A	16	26.5	24	36	36	02072#17	G2SHTG20S
	250	25	G 1A	18	31.5	30.5	41	46	02072#18	G2SHTG25S
	160	30	G 1 1/4A	20	37	35.5	50	55	02072#19	G2SHTG30S

**G2C**  
四通管接头  
Union Cross

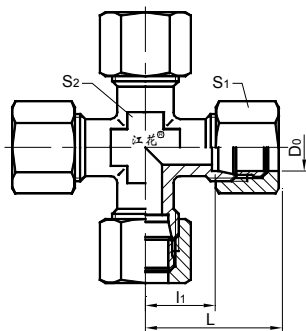

系列	PN	D0	I1	L	S1	S2	产品编号	型号
Series	PN	D0	I1	L	S1	S2	Product No	Type
L	315	6	12	29	14	12	02073#01	G2C06L
	315	8	14	31.5	17	14	02073#02	G2C08L
	315	10	15	34	19	17	02073#03	G2C10L
	315	12	17	36.5	22	19	02073#04	G2C12L
	315	15	21	41	27	19	02073#05	G2C15L
	315	18	23.5	44	32	24	02073#06	G2C18L
	160	22	27.5	51	36	27	02073#07	G2C22L
	160	28	30.5	54.5	41	36	02073#08	G2C28L
	160	35	34.5	61	50	41	02073#09	G2C35L
	160	42	40	67.5	60	50	02073#10	G2C42L
S	400	6	16	33.5	17	12	02073#11	G2C06S
	400	8	17	35.5	19	14	02073#12	G2C08S
	400	10	17.5	37.5	22	17	02073#13	G2C10S
	400	12	21.5	41.5	24	17	02073#14	G2C12S
	400	14	22	43.5	27	19	02073#15	G2C14S
	400	16	24.5	46.5	30	24	02073#16	G2C16S
	400	20	26.5	52	36	27	02073#17	G2C20S
	400	25	30	58	46	36	02073#18	G2C25S
	400	30	35.5	67.5	50	41	02073#19	G2C30S

**G2SS**  
支撑套  
Support Sleeve

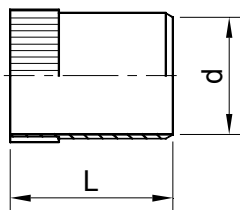

管子内径	产品编号	型号	管子内径	产品编号	型号
Tube I.D.	d	L	Tube I.D.	d	L
4	2.6	14.0	18	16.2	20.0
4.5	3.1	14.0	19	17.2	16.0
5	3.6	14.0	20	18.2	21.5
6	4.6	14.0	21	19.2	21.5
7	5.6	15.5	22	20.2	23.5
8	6.6	15.5	24	22.2	23.5
9	7.6	15.5	25	23.2	23.5
10	8.6	15.5	26	24.2	23.5
12	10.2	17.0	27	25.2	23.5
13	11.2	17.0	30	27.8	26.5
14	12.2	17.0	31	28.8	26.5
15	13.2	20.0	32	29.8	26.5
16	14.2	20.0	33	30.8	26.5
17	15.2	20.0	38	35.8	21.0

## G2CAP

### 管帽 Cap

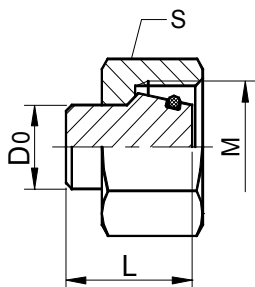

系列 Series	PN	D0	M	L	S	产品编号 Product No.	型号 Type
L	250	6	M12×1.5	18.5	14	02075#01	G2CAP06L
	250	8	M14×1.5	18.5	17	02075#02	G2CAP08L
	250	10	M16×1.5	20	19	02075#03	G2CAP10L
	250	12	M18×1.5	20.5	22	02075#04	G2CAP12L
	250	15	M22×1.5	20.5	27	02075#05	G2CAP15L
	250	18	M24×1.5	22.5	32	02075#06	G2CAP18L
	160	22	M30×2	25	36	02075#07	G2CAP22L
	160	28	M36×2	25.5	41	02075#08	G2CAP28L
	160	35	M45×2	30	50	02075#09	G2CAP35L
	160	42	M52×2	30	60	02075#10	G2CAP42L
S	400	6	M14×1.5	18.5	17	02075#11	G2CAP06S
	400	8	M16×1.5	18.5	19	02075#12	G2CAP08S
	400	10	M18×1.5	20	22	02075#13	G2CAP10S
	400	12	M20×1.5	20.5	24	02075#14	G2CAP12S
	400	14	M22×1.5	22.5	27	02075#15	G2CAP14S
	400	16	M24×1.5	23.5	30	02075#16	G2CAP16S
	400	20	M30×2	28.5	36	02075#17	G2CAP20S
	400	25	M36×2	29	46	02075#18	G2CAP25S
	400	30	M42×2	30.5	50	02075#19	G2CAP30S

## G2PL

### 堵头 Plug

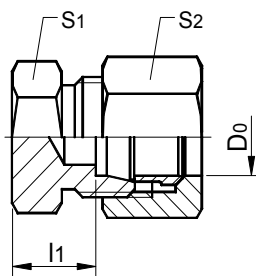

系列 Series	PN	D0	l1	S1	S2	产品编号 Product No.	型号 Type
L	250	6	7	14	15	02076#01	G2PL06L
	250	8	8	14	17	02076#02	G2PL08L
	250	10	9	17	19	02076#03	G2PL10L
	250	12	10	19	22	02076#04	G2PL12L
	250	15	11	24	27	02076#05	G2PL15L
	250	18	11.5	27	30	02076#06	G2PL18L
	160	22	13.5	32	36	02076#07	G2PL22L
	160	28	14.5	41	41	02076#08	G2PL28L
	160	35	14.5	46	50	02076#09	G2PL35L
	160	42	16	55	60	02076#10	G2PL42L
S	400	6	11	14	17	02076#11	G2PL06S
	400	8	13	17	19	02076#12	G2PL08S
	400	10	12.5	19	22	02076#13	G2PL10S
	400	12	14.5	22	24	02076#14	G2PL12S
	400	14	16	24	27	02076#15	G2PL14S
	400	16	15.5	27	30	02076#16	G2PL16S
	400	20	17.5	32	36	02076#17	G2PL20S
	400	25	20	41	41	02076#18	G2PL25S
	400	30	20.5	46	50	02076#19	G2PL30S



**G2M**

卡套螺母

M Nut

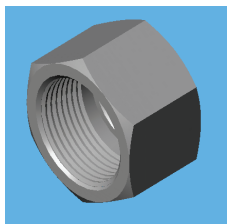

系列				产品编号	型号
Series	D0	M	S	Product No.	Type
L	6	M12×1.5	14	02077#01	G2M06L
	8	M14×1.5	17	02077#02	G2M08L
	10	M16×1.5	19	02077#03	G2M10L
	12	M18×1.5	22	02077#04	G2M12L
	15	M22×1.5	27	02077#05	G2M15L
	18	M24×1.5	32	02077#06	G2M18L
	22	M30×2	36	02077#07	G2M22L
	28	M36×2	41	02077#08	G2M28L
	35	M45×2	50	02077#09	G2M35L
	42	M52×2	60	02077#10	G2M42L
S	6	M14×1.5	17	02077#11	G2M06S
	8	M16×1.5	19	02077#12	G2M08S
	10	M18×1.5	22	02077#13	G2M10S
	12	M20×1.5	24	02077#14	G2M12S
	14	M22×1.5	27	02077#15	G2M14S
	16	M24×1.5	30	02077#16	G2M16S
	20	M30×2	36	02077#17	G2M20S
	25	M36×2	46	02077#18	G2M25S
	30	M42×2	50	02077#19	G2M30S

**G2CR**

卡套

Cutting Ring

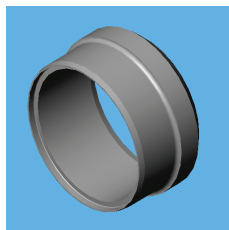

系列			产品编号	型号
Series	D0		Product No.	Type
L	6		02078#01	G2CR06L
	8		02078#02	G2CR08L
	10		02078#03	G2CR10L
	12		02078#04	G2CR12L
	15		02078#05	G2CR15L
	18		02078#06	G2CR18L
	22		02078#07	G2CR22L
	28		02078#08	G2CR28L
	35		02078#09	G2CR35L
	42		02078#10	G2CR42L
S	14		02078#11	G2CR14S
	16		02078#12	G2CR16S
	20		02078#13	G2CR20S
	25		02078#14	G2CR25S
	30		02078#15	G2CR30S

ISO 9974-1 公制螺纹油口和旋入端 (DIN3852 第一部份)

ISO9974-1 Ports and Stud Ends with Metrical Straight Thread (DIN 3852, Part 1)

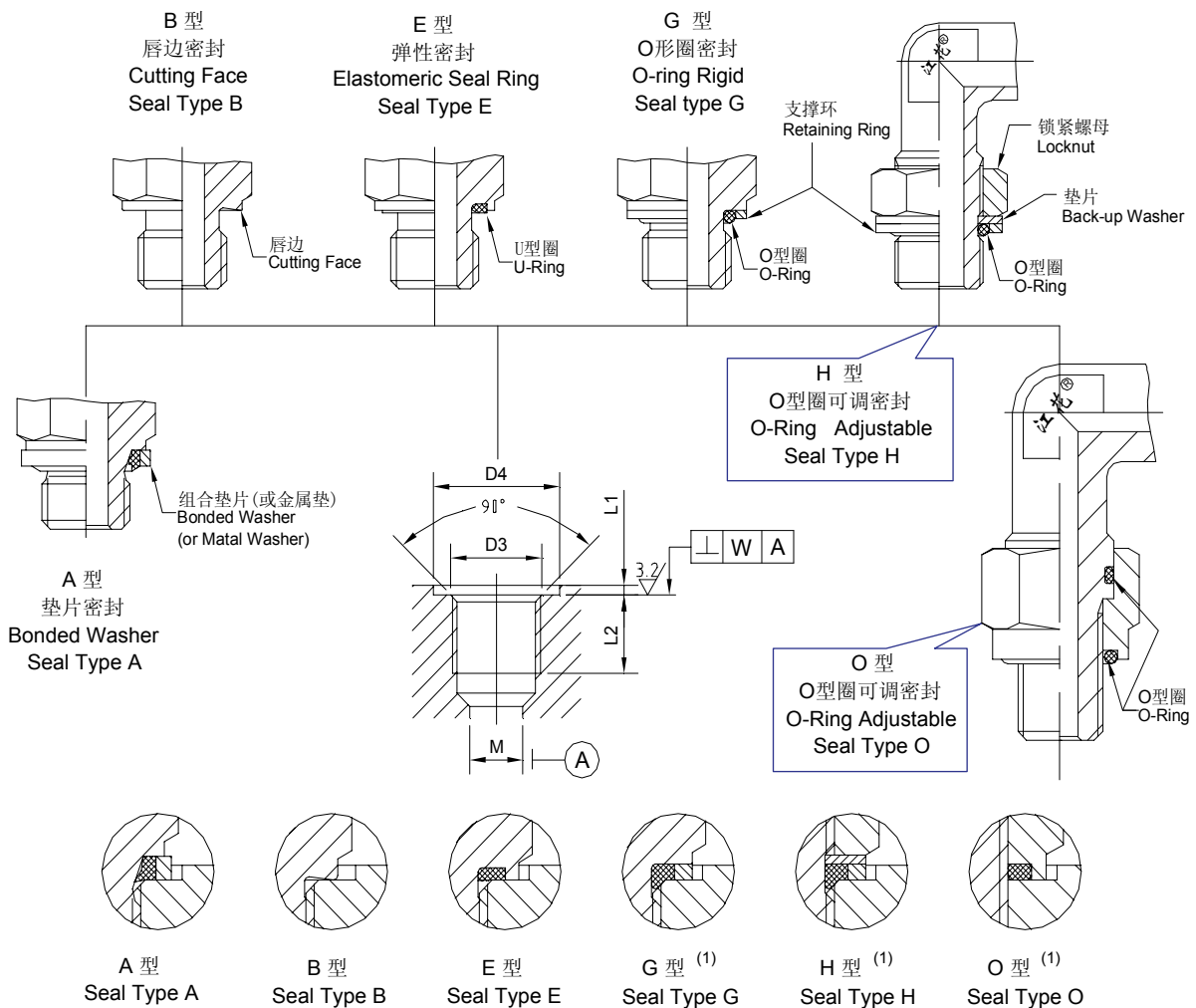

ISO 9974-1油口尺寸 Port Detail-ISO 9974-1

螺纹尺寸 M	D3 (mm)	D4最小 (mm)			L1最大 L1max (mm)	L2最小 L2min (mm)	W (mm)
		A型、B型、E型 Type A, B & E	G型、H型 (1) Type G & H	O型 (1) Type O			
M10×1	10.2	15	16	-	1	8	0.1
M12×1.5	12.5	18	19	-	1.5	12	
M14×1.5	14.2	20	21	23	1.5	12	
M16×1.5	16.2	23	24	25	1.5	12	
M18×1.5	18.2	25	26	25	2	12	
M20×1.5	20.2	27	27	-	2	14	
M22×1.5	22.2	28	29	31	2.5	14	0.2
M27×2	27.2	33	34	41	2.5	16	
M33×2	33.3	41	43	47	2.5	18	
M42×2	42.3	51	52	55	2.5	20	
M48×2	48.3	56	57	61	2.5	22	

(1) G型、H型和O型密封型式和尺寸不包含在ISO 9974-1中。

Seal types G, H and O are not covered in ISO 9971-1.

ISO 6149公制螺纹油口和旋入端 (SAE 2244-1/DIN3852 第三部份)

ISO 6149-1 Ports and Stud Ends with Metrical Straight Thread (SAE 2244-1/DIN 3852, Part 3)

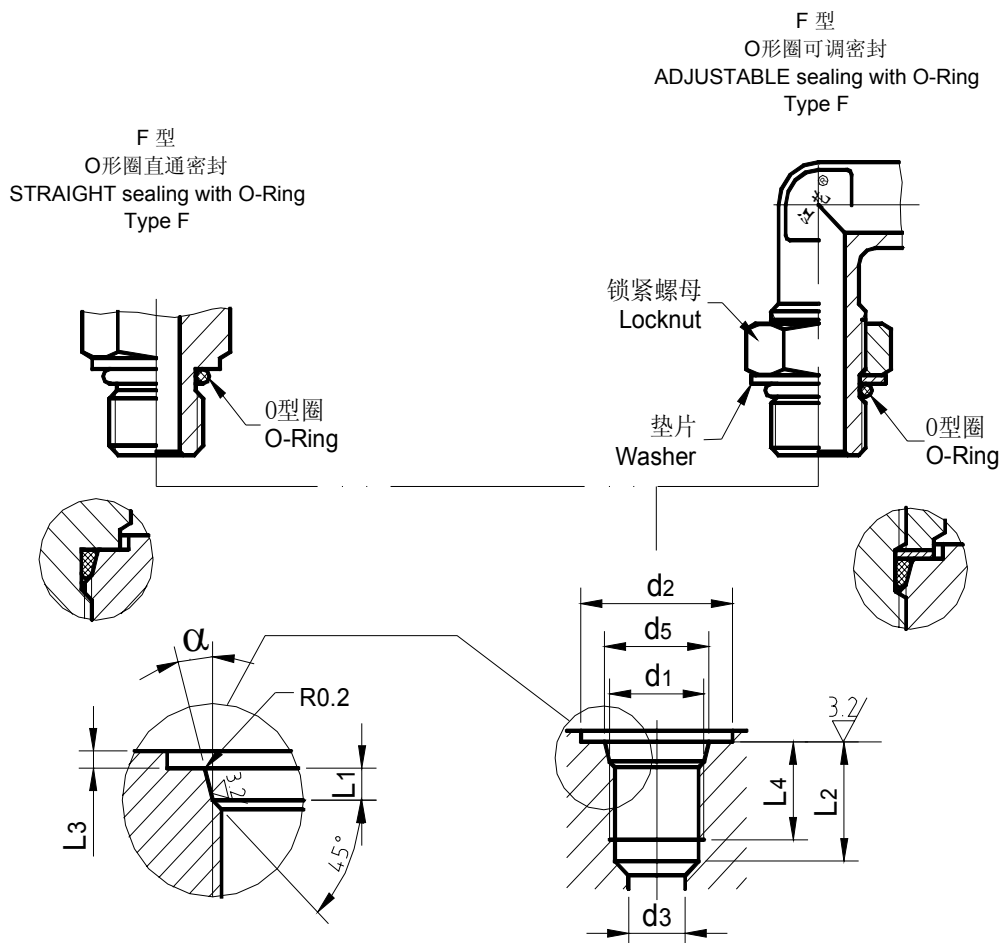

ISO 6149-1 Port Detail

螺纹尺寸 Thread Size $d_1$	$d_2$ 最小 $d_2$ min (mm)	$d_3$ 参考 $d_3$ ref. (mm)	$d_5$ +0.10 (mm)	$L_1$ +0.4 (mm)	$L_2$ 最小 $L_2$ min (mm)	$L_3$ 最大 $L_3$ max (mm)	$L_4$ 最小 $L_4$ min (mm)	$\alpha \pm 1^\circ$
M8×1	14	3	9.1	1.6	11.5	1	10	12
M10×1	16	4.5	11.1	1.6	11.5	1	10	12
M12×1.5	19	6	13.8	2.4	14	1.5	11.5	15
M14×1.5	21	7.5	15.8	2.4	14	1.5	11.5	15
M16×1.5	24	9	17.8	2.4	15.5	1.5	13	15
M18×1.5	26	11	19.8	2.4	16.5	2	14.5	15
M20×1.5	27	-	21.8	2.4	16.5	2	14.5	15
M22×1.5	29	14	23.8	2.4	18	2	15.5	15
M27×2	34	18	29.4	3.1	22	2	19	15
M30×2	38	18	32.4	3.1	22	2	19	15
M33×2	43	23	35.4	3.1	22	2.5	19	15
M42×2	52	30	44.4	3.1	22.5	2.5	19.5	15
M48×2	57	36	50.4	3.1	25	2.5	22	15

SAE J1926-1 UN/UNF 螺纹油口和旋入端 (ISO 11926-1)

SAE J1926-1 Ports and Stud Ends with UN/UNF Thread (ISO 11926-1)

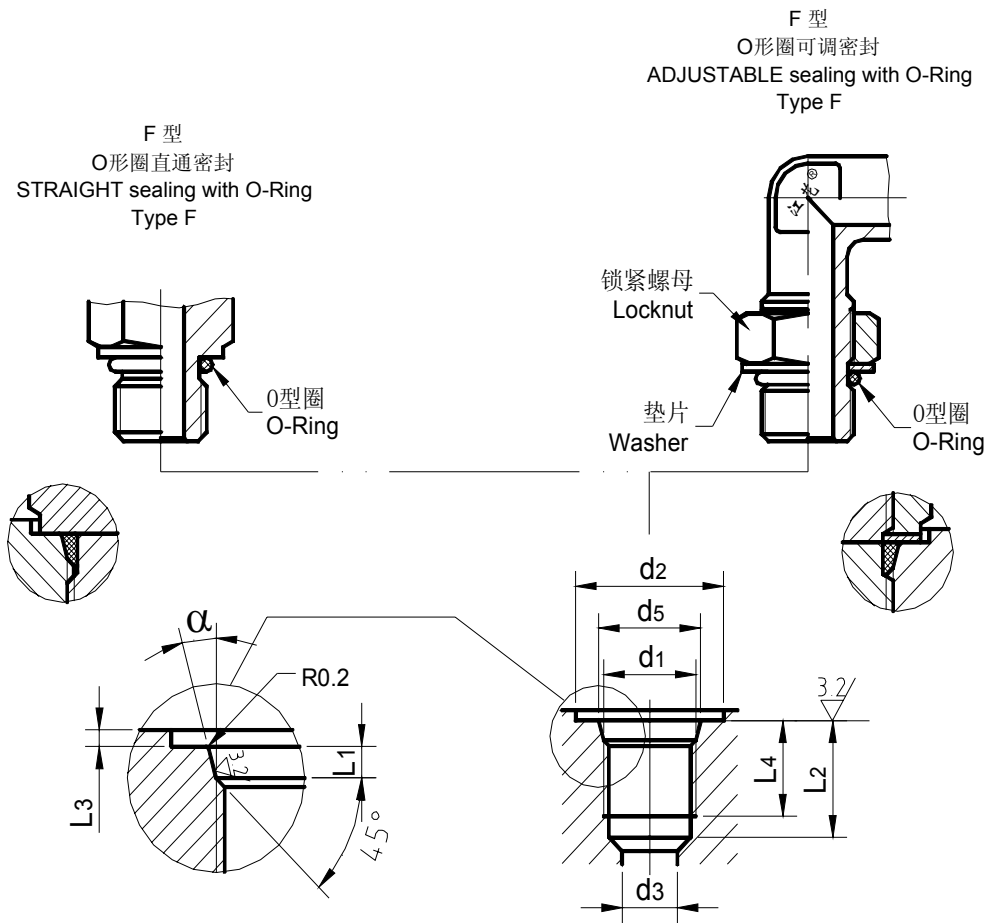

SAE J1926-1 Port Detail (ISO 11926-1)

螺纹尺寸 Thread Size d1	d2 最小 d2 min (mm)	d3 参考 d3 ref. (mm)	d5 +0.10 (mm)	L1 +0.4 (mm)	L2 最小 L2 min (mm)	L3 最大 L3 max (mm)	L4 最小 L4 min (mm)	$\alpha \pm 1^\circ$
5/16-24 UNF-2B	17	1.6	9.1	1.9	12	1.6	10	12
3/8-24 UNF-2B	19	3.2	10.7	1.9	12	1.6	10	12
7/16-20UNF-2B	21	4.4	12.4	2.4	14	1.6	11.5	12
1/2-20UNF-2B	23	6	14	2.4	14	1.6	11.5	12
9/16-18UNF-2B	25	7.5	15.6	2.5	15.5	1.6	12.7	12
3/4-16UNF-2B	30	10	20.6	2.5	17.5	2.4	14.3	15
7/8-14UNF-2B	34	12.5	23.9	2.5	20	2.4	16.7	15
1 1/16-12UN-2B	41	16	29.2	3.3	23	2.4	19	15
1 3/16-12UN-2B	45	18	32.3	3.3	23	2.4	19	15
1 5/16-12UN-2B	49	21	35.5	3.3	23	3.2	19	15
1 5/8-12UN-2B	58	27	43.5	3.3	23	3.2	19	15
1 7/8-12UN-2B	65	33	49.8	3.3	23	3.2	19	15

ISO 1179-1英制螺纹油口和旋入端 (DIN3852 第二部份)

ISO 1179-1 Ports and Stud Ends with Whitworth BSPP Thread "G" (DIN 3852, Part 2)

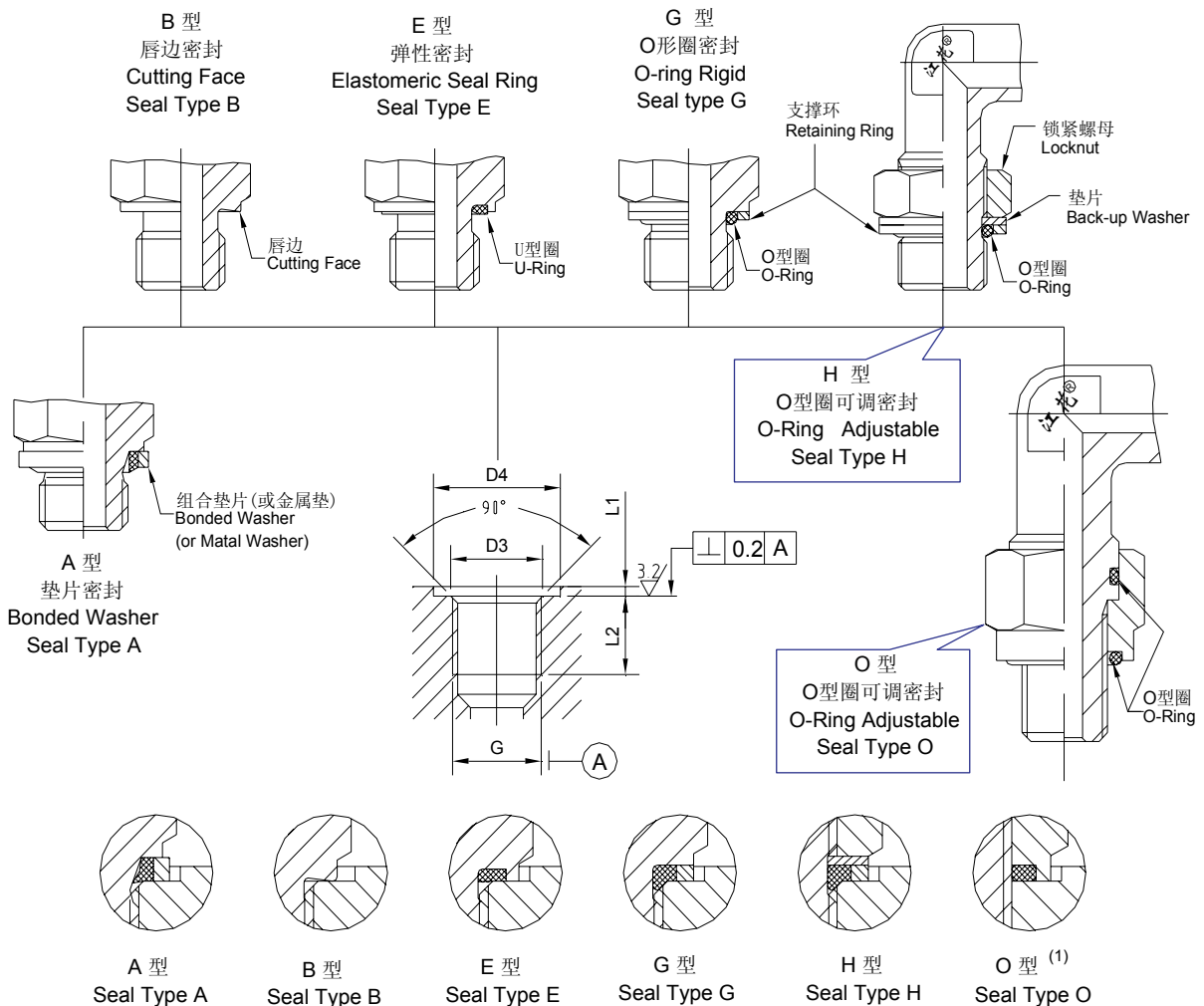

ISO 1179-1油口尺寸 Port Detail-ISO 1179-1

螺纹尺寸 G	D3 (mm)	D4最小 (mm)			L1最大 L1max (mm)	L2最小 L2min (mm)
		窄型 A、B、E型 Narrow Type A, B & E	宽型 G、H型 Wide Type G & H	O型 (1) Type O		
G 1/8-28	9.9	15	17.2	-	1.0	8.5
G 1/4-19	13.3	18	20.7	23	1.5	12.5
G 3/8-19	16.8	23	24.5	25	2.0	12.5
G 1/2-14	21.1	28	34.0	31	2.5	14.5
G 3/4-14	26.6	33	40.0	41	2.5	16.5
G 1-11	33.5	41	46.1	47	2.5	18.5
G 1 1/4-11	42.2	51	54.0	55	2.5	20.5
G 1 1/2-11	48.1	56	60.5	61	2.5	22.5

(1) O型密封型式和尺寸不包含在ISO 1179-1中。

Seal type O is not covered in ISO 1179-1.

锥螺纹ZM、BSPT (R) 和NPT螺纹油口和旋入端  
Ports and Stud Ends with ZM, BSPT & NPT Thread

ZM米制锥螺纹端  
锥螺纹密封  
Stud Thread ZM  
sealing with Tapered thread

BSPT英制锥螺纹端  
锥螺纹密封  
Stud Thread BSPT (R)  
sealing with Tapered thread

NPT锥螺纹端  
锥螺纹密封  
Stud Thread NPT  
sealing with Tapered thread

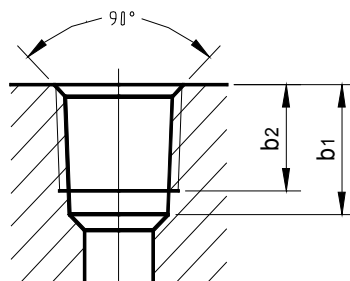
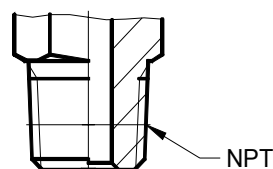
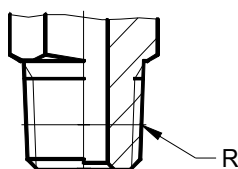
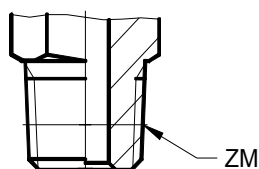

米制锥螺纹油口尺寸

Metrical Tapered Thread ZM Port Dimensions

螺纹尺寸 Thread Size ZM	钻孔深度 Tap Drill Depth	螺纹长度 Thread Length
ZM	b1 (mm)	b2 (mm)
ZM8×1	7.5	5.5
ZM10×1	7.5	5.5
ZM12×1.5	10.5	8.5
ZM14×1.5	10.5	8.5
ZM16×1.5	10.5	8.5
ZM18×1.5	10.5	8.5
ZM20×1.5	12.5	10.5
ZM22×1.5	12.5	10.5
ZM33×2	14.5	12
ZM42×2	15.5	13
ZM48×2	16	13

BSPT和NPT螺纹油口尺寸

BSPT Thread and NPT Thread Port Dimensions

螺纹尺寸 Thread Size		钻孔深度 Tap Drill Depth	螺纹长度 Thread Length
BSPT	NPT	b1 (mm)	b2 (mm)
R 1/8-28	1/8-27 NPT	9.7	7.9
R 1/4-19	1/4-18 NPT	11.9	11.2
R 3/8-19	3/8-18 NPT	13.5	11.9
R 1/2-14	1/2-14 NPT	17.5	15
R 3/4-14	3/4-14 NPT	19.1	16
R 1-11	1-11 1/2 NPT	21.3	19.1
R 1 1/4-11	1 1/4-11 1/2NPT	21.3	19.8
R 1 1/2-11	1 1/2-11 1/2NPT	22.4	20.6
R 2-11 1/2	2-11 1/2 NPT	23.1	20.6