



简介

NB系列针形阀设计应用于各种仪表测量管路，额定工作压力6000 psig (414 barg)，采用自动定心非旋转式锥形阀芯和螺纹阀盖结构，结构精巧，性能可靠，使用维护方便。

Introduction

NB series needle valves are designed for various instrument measurement Tubing system up to 6,000 psig (414 barg) rating. Complete with self centering non rotational tip and threaded bonnet structure. With such light construction, the performance is reliable which is easy to use and maintain.

特点

- ◎ 阀体采用冷拉四方型钢加工,阀盖与阀体采用螺纹连接.
- ◎ 采用活动阀芯与阀杆铆接，在阀门关闭的瞬间，阀芯只上下移动但不转动，避免了密封面刮伤
- ◎ 填料螺栓的设计，随时填料调整
- ◎ 滚轧阀杆螺纹
- ◎ 阀杆螺纹位于填料上方，避免介质的冲刷与侵蚀
- ◎ 在全开位置有可靠的上密封性能
- ◎ 标配聚四氟乙烯填料，可选用柔性石墨填料

- ◎ 阀体型式有直通和角式可供选择
- ◎ 连接型式多样：卡套连接，活接对焊，内螺纹，外螺纹，承插焊，法兰连接
- ◎ 100%工厂试验

Features

- ◎ The body is fabricated by cold-drawn cubic channel steel. The bonnet is connected to the body by thread.
- ◎ We adopt riveting procedure of the active stem tip and stem. All the action in the fitting moves axially instead of in a rotary motion during the closure moment of the valve to reduce the seat galling.
- ◎ The packing can be adjusted because of the design of the packing bolt.
- ◎ Rolled stem operating threads
- ◎ Threads above packing can avoid the corrosion from medium.
- ◎ Safety back seating seal in fully open position
- ◎ PTFE packing standard, optional Graphite
- ◎ Body type: straight pattern and angle pattern
- ◎ Various connection: ferrules, live butt-welding, female thread, male thread, socket welding, flange
- ◎ 100% factory tested

技术规范

- ◎ 最高工作压力：
不锈钢、合金600：6000 psig (414 bar)
合金400：5000 psig (344 bar)
- ◎ 公称通径：6-20 mm
- ◎ 许用温度范围：
PTFE填料：-54~232℃
柔性石墨填料：-54~538℃
- ◎ 接口型式和尺寸：
接口型式多种多样，可根据用户需要灵活配置。常用接口如下：
 - 双卡套连接DF：
米制管 ϕ 10-22 mm；英制管 3/8"-3/4"
 - 活接对焊UBW： ϕ 12-34 mm

Specification

- ◎ Maximum working pressures：
Stainless steel and Alloy 600: 6000 psig (414 bar)
Alloy 400: 5000 psig (344 bar)
- ◎ DN: 6-20 mm
- ◎ Applicable temperature range：
PTFE packing: -54~232℃
Soft graphite packing: -54~538℃
- ◎ Interface type and size
The interfaces are various and can be decided by customer's requirement. The common interfaces are as follows.
 - Double ferrules (DF):
Metric tube of 10-22 mm; Fractional tube of 3/8"-3/4"
 - Union butt welding (UBW): 12-34 mm

- NPT外螺纹 (N) : 1/4", 3/8", 1/2", 3/4" ■ NPT male thread (N): 1/4", 3/8", 1/2", 3/4"
- NPT内螺纹(FN): 1/4",3/8",1/2",3/4",1" ■ NPT female thread (FN): 1/4", 3/8", 1/2", 3/4",1"
- BSPT外螺纹(R): 1/4",3/8",1/2",3/4",1" ■ BSPT male thread 1/4", 3/8", 1/2", 3/4", 1"
- BSPT内螺纹(Rc): 1/4",3/8",1/2",3/4",1" ■ BSPT female (Rc) : 1/4", 3/8", 1/2", 3/4", 1"
- T管承插焊(TSW): 12-34 mm ■ Tube socket welding (TSW): 12-25 mm
- P管承插焊(PSW): 1/4",3/8",1/2",3/4",1" ■ Pipe socket welding (PSW): 1/4",3/8",1/2",3/4",1"

压力温度等级 Pressure-Temperature Ratings

ASME等级 ASME Class	2500		
材料组别 Material Group	2.2	3.4	3.5
材料名称 Material Name	316 SS	合金400 Alloy 400	合金600 Alloy 600
温度 Temperature, °C (°F)	工作压力 Working Pressure, psig (bar)		
-53 to 38 (-65 to 100)	6000 (413)	5000 (344)	6000 (413)
93 (200)	5160 (355)	4400 (303)	5600 (385)
121 (250)	4910 (338)	4260 (293)	5460 (376)
148 (300)	4660 (321)	4120 (283)	5320 (366)
176 (350)	4470 (307)	4050 (279)	5220 (359)
204 (400)	4280 (294)	3980 (274)	5120 (352)
232 (450)	4130 (284)	3970 (273)	5030 (346)
260 (500)	3980 (274)	—	4940 (340)
315 (600)	3760 (259)	—	4780 (329)
343 (650)	3680 (254)	—	4700 (323)
371 (700)	3620 (249)	—	4640 (319)
398 (750)	3560 (245)	—	4430 (305)
426 (800)	3520 (242)	—	4230 (291)
454 (850)	3480 (239)	—	4060 (279)
482 (900)	3460 (238)	—	3745 (258)
510 (950)	3220 (222)	—	2725 (187)
537 (1000)	3030 (208)	—	1800 (124)

注: 额定值是以选配石墨填料的针形阀为准. 标准PTFE填料温度额定值:232°C

Note: Ratings are based on needle valves with optional graphite packing. Temperature rating for standard PTFE packing: 232°C

结构材料 Materials of Construction

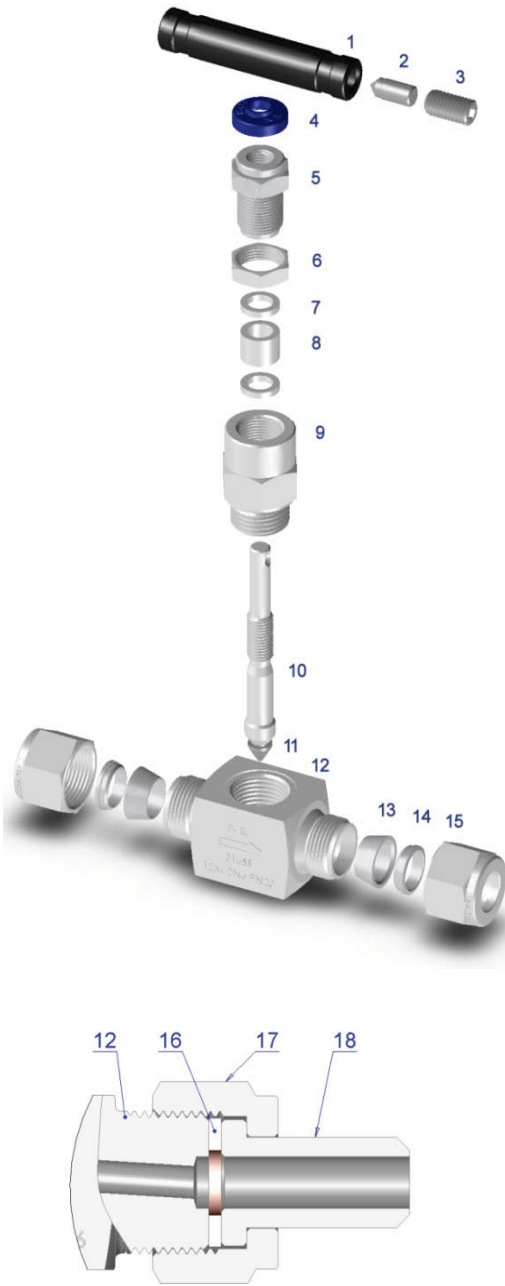

活接对焊型式(UBW)
Union butt welding type

序号 No.	元件 Components	阀体材料 Body material				
		碳钢 CS	304SS	316SS	合金 Alloy 400	合金 Alloy 600
1	手柄 Handle	阳极化铝, 304SS, 铸铁手轮 Anodized aluminum, 304SS, Iron hand wheel				
2	手柄顶针 Handle pin	不锈钢或镀镍镉钢 Stainless steel or Nickel cadmium-plated steel				
3	紧定螺钉 Set screw	不锈钢或镀镍镉钢 Stainless steel or Nickel cadmium-plated steel				
4	防尘盖 Dust cap	塑料 Plastic				
5	填料螺栓 Packing bolt	35	416SS			
6	薄螺母 Thin nut	Q235A	304SS	316SS		
7	填料垫 Packing washer	Q335A	304SS	316SS	合金 Alloy R-405	合金 Alloy 600
8	填料 packing	聚四氟乙烯 石墨 PTFE or Graphite				
9	阀座 Bonnet	25	304SS	316SS	合金 Alloy R-405	合金 Alloy 600
10	阀杆 Stem	304SS	304SS		合金 Alloy R-405	合金 Alloy 600
11	自定心阀芯 self centering stem tip	316SS 选项焊硬质合金 316SS or weld Stellite optional			合金 Alloy R-405	合金 Alloy 600
12	阀体 body	25	304SS	316SS	合金 Alloy 400	合金 Alloy 600
13	前卡套 Front ferrule	—	304SS	316SS	合金 Alloy R-405	合金 Alloy 600
14	后卡套 Back ferrule	—	304SS	316SS	合金 Alloy R-405	合金 Alloy 600
15	卡套螺母 Ferrule nu	—	304SS	316SS	合金 Alloy R-405	合金 Alloy 600
16	垫片 washer	聚四氟乙烯, 铜, 铝 PTFE, copper or aluminum				
17	螺母 Nut	Q235A	304SS	316		
18	焊接接管 welding nipple	25	304SS	316SS	合金 Alloy R-405	合金 Alloy 600

注：表中结构材料为我公司典型配置，根据介质及温度状况可能有变动，也可按顾客要求制造。

Note: The material in the sheet is used on manufacturing the common product in our company. We can manufacture as the customer's requirements according to the change of the medium and temperature condition.

NB系列针形阀

NB Series Needle Valves



尺寸 Dimensions

尺寸仅供参考, 可能变动。

Dimensions are for reference only and are subject to change.

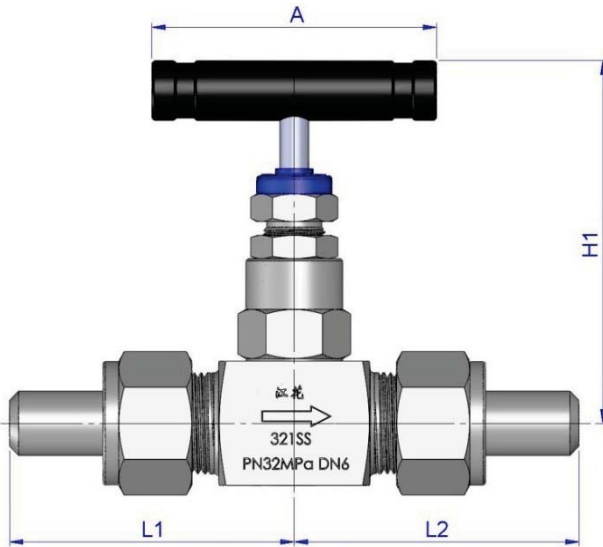

直通阀 Straight pattern: NB6-UBW14

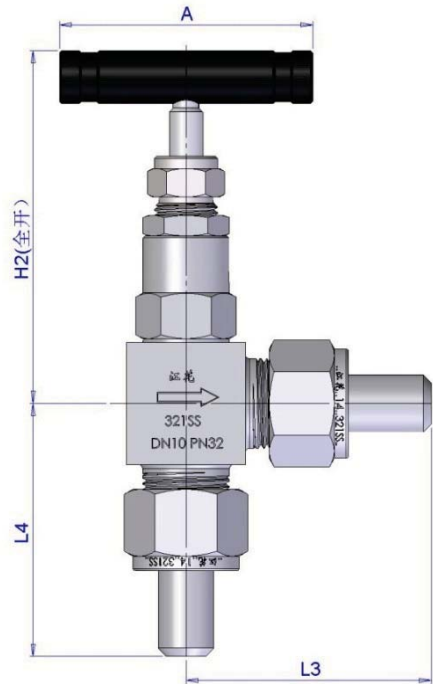

角式阀 Angle pattern: NB10A-UBW15

规格尺寸表 Table of model and dimensions

基本型号 Basic Model	连接型式/尺寸 Connection Type and Size		尺寸 size (mm)						
	进口 Inlet	出口 Outlet	A	L1	L2	H1	L3	L4	H2
NB6系列 (DN6) NB6 Series									
NB6(A)-DF10M	双卡套公制管10mm Double ferrules for metric tube	同进口 Same as inlet	64.0	37.5	37.5	79.0	34.5	34.5	79.0
NB6(A)-DF12M	双卡套公制管12mm Double ferrules for metric tube			39.3	39.3		36.3	36.3	
NB6(A)-DF3/8	双卡套英制管3/8" Double ferrules for fractional tube			37.5	37.5		34.5	34.5	
NB6(A)-DF1/2	双卡套英制管1/2" Double ferrules for fractional tube			39.3	39.3		36.3	36.3	
NB6(A)-UBW12	活接对焊12mm Union butt welding			64.0	64.0		61.0	61.0	
NB6(A)-UBW14	活接对焊14mm Union butt welding			64.0	64.0		61.0	61.0	
NB6(A)-FN1/4	1/4"NPT内螺纹 Female NPT			28.0	28.0		26.0	26.0	
NB6(A)-FN3/8	3/8"NPT内螺纹 Female NPT			28.0	28.0		26.0	26.0	
NB6(A)-FN1/2	1/2"NPT内螺纹 Female NPT			32.0	32.0		80.5	33.0	

规格尺寸表 Table of model and dimensions

基本型号 Basic Model	连接型式/尺寸 Connection Type and Size		尺寸 size (mm)							
	进口 Inlet	出口 Outlet	A	L1	L2	H1	L3	L4	H2	
NB6(A)-TSW14	T管承插焊14mm Tube socket weld	同进口 Same as inlet	64.0	28.0	28.0	79.0	26.0	26.0	79.0	
NB6-MFN1/4	1/4"NPT外螺纹 Male thread	1/4"NPT内螺纹 Female thread		30.0	28.0		—	—	—	
NB6-MFN3/8	3/8"NPT外螺纹 Male thread	3/8"NPT内螺纹 Female thread		30.0	28.0		—	—	—	
NB6-MFN1/2	1/2"NPT外螺纹 Male thread	1/2"NPT内螺纹 Female thread		38.0	32.0		—	—	—	
NB10系列 (DN10) NB10 series										
NB10(A)-DF12M	双卡套公制12mm Metric tube of double ferrules	同进口 Same as inlet	64.0	42.3	42.3	89.0	37.8	37.8	87.5	
NB10(A)-DF14M	双卡套公制14mm Metric tube of double ferrules									
NB10(A)-DF1/2	双卡套英制1/2" Fractional tube of double ferrules									
NB10(A)-DF3/4	双卡套英制3/4" Fractional tube of double ferrules									
NB10(A)-UBW14	活接对焊14mm Union butt weld			64.0	64.0	62.0	62.0			
NB10(A)-UBW18	活接对焊18mm Union butt weld			32.0	32.0	33.0	33.0			
NB10(A)-FN1/2	1/2"NPT内螺纹 Female thread									
NB10(A)-FN3/4	3/4"NPT内螺纹 Female thread			35.0	35.0	90.0	35.5	35.5		90
NB10(A)-TSW14	T管承插焊14mm Tube socket weld			29.0	29.0	79.0	27.0	27.0		87.5
NB10(A)-TSW16	T管承插焊16mm Tube socket weld									
NB10(A)-TSW18	T管承插焊18mm Tube socket weld									

常见接口型式举例: Example for connections

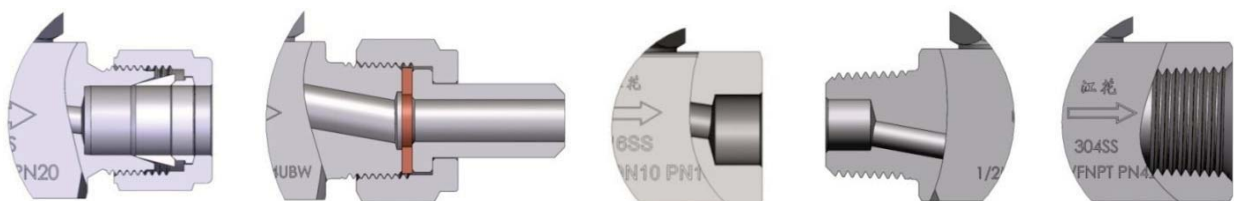

双卡套 Double ferrules 活接对焊 Union butt welding 承插焊 Scott weld 外螺纹 male 内螺纹 Female

NB系列针形阀

NB Series Needle Valves

江花®
JIANGHUA

NB15,20系列 NB15 and NB20 Series

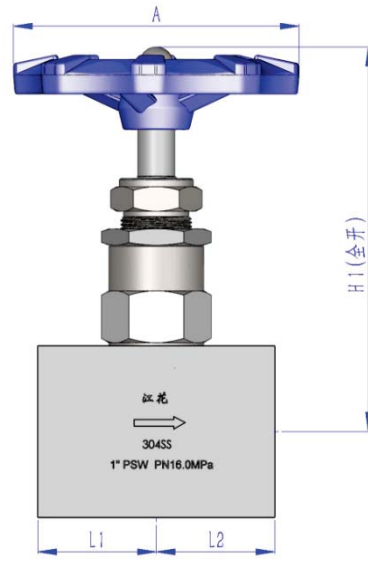
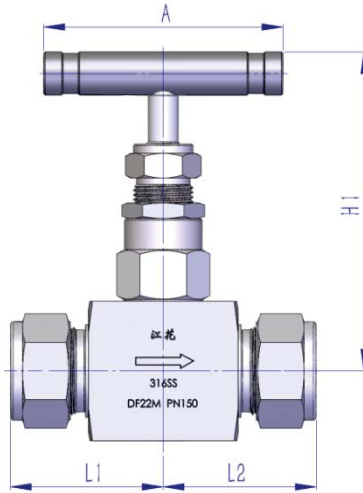

基本型号 Basic Model	连接型式/尺寸 Connection Type and Size		尺寸 size (mm)				
	进口 Inlet	出口 Outlet	A	L1	L2	H1	H2
NB15系列 (DN15) NB15 Series							
NB15-UBW22	活接对焊 22mm Union butt welding	同进口 same with inlet	80.0	74.0	74.0	103.0	95
NB15-UBW27	活接对焊 27mm Union butt welding		φ100	78.0	78.0	111.5	103.5
NB15-DF20M	双卡套公制 20mm Metric tube of double ferrules		80.0	51.1	51.1	103.0	95
NB15-DF22M	双卡套公制 22mm Metric tube of double ferrules			40.0	40.0		
NB15-FN3/4	3/4"NPT内螺纹 Female thread		35.0	35.0			
NB15-TSW22	T管承插焊22mm Tube socket weld		35.0	35.0			
NB15-TSW25	T管承插焊25mm Tube socket weld		35.0	35.0			
NB15-PSW1/2	P管承插焊1/2" Pipe socket weld		35.0	35.0			
NB20系列 (DN20) NB20 Series							
NB20-UBW34	活接对焊34mm Union butt welding	同进口 same with inlet	φ110	92.0	92.0	140.0	129.2
NB20-FN1	1"NPT内螺纹 Female thread			50.0	50.0		
NB20-TSW28	T管承插焊28mm Tube socket weld						
NB20-PSW3/4	P管承插焊3/4 Pipe socket weld						
NB20-PSW1	P管承插焊1" Pipe socket weld						

订购须知 Ordering information

阀门系列 Series	阀体型式 Body	密封面材料 Seat Material	填料材质 Packing material	进口型式 Inlet Type	进口尺寸 Inlet Size	出口型式 Outlet type	出口尺寸 Outlet Size	阀体材料 Body Material	手柄 Handle	
NB6	直通阀 straight	与阀体同 Same as 司太立合金 Stellite	聚四氟乙烯 PTFE	NPT外螺纹 NPT	1/4" - 3/4"	与进口相同 Same as inlet	与进口相同 Same as inlet	S1	黑色氧化铝棒 Black Aluminum bar	
	角式阀 Angle									
NB10	A	Y	G	NPT内螺纹 Female NPT	1/4" - 1"	与进口相同 Same as inlet	与进口相同 Same as inlet	S4	蓝色氧化铝棒 Blue Aluminum bar	
NB15				BSPT外螺纹 Male BSPT	1/4" - 3/4"	与进口相同 Same as inlet	与进口相同 Same as inlet	S6	304不锈钢棒 304SS bar	
NB20				BSPT内螺纹 Female BSPT	1/4" - 1"	与进口相同 Same as inlet	与进口相同 Same as inlet	S6L	蓝色铸铁手轮 Blue Iron hand	
				双卡套(米制管) Double ferrule (Metric tube)	10 - 25	标识方法同进口型式和 尺寸 Specify in the same way as inlet Type and inlet size	与进口相同 Same as inlet	碳钢 Carbon steel	红色铸铁手轮 Red Iron hand wheel	
				双卡套(英制管) Double ferrule (Fractional tube)	3/8" - 1"			M	合金 400 Alloy 400	
				活接对焊 Union butt weld	12 - 34			INC	合金 600 Alloy 600	
				T管承插焊 Tube socket weld	12 - 34					
				P管承插焊 Pipe socket weld	1/4" - 1"					

型号举例说明:

For example

NB6-DF12M-S6

NB6: NB针形阀 DN6系列, 直通型式
密封面材料同阀体,
PTFE填料
-DF12M: 进口型式为公制管双卡套,
尺寸f12mm
出口型式和尺寸与进口相同
-S6: 阀体材料为316不锈钢
黑色铝氧化圆棒手柄

NB6: DN6 series of NB needle valve, Straight pattern,
The seat material is the same as the body,
PTFE packing
-DF12M: The inlet type is metric tube of double ferrules,
Size is 12 mm.
The outlet type and size is same as the inlet.
-S6: Body material is 316SS
The handle is black aluminum bar

NB10A-G-TSW16-TSW14-S1-2

NB10A: NB针形阀 DN10系列, 角式阀
阀座材料同阀体
-G: 石墨填料
-TSW16: 进口型式为Tube管承插焊接,
进口尺寸 ϕ 16mm
-TSW14: 出口型式为Tube管承插焊接,
出口尺寸 ϕ 14mm
-S4: 阀体材料为304不锈钢
-1: 手柄采用304不锈钢圆棒手柄

NB10A: DN10 series of NB needle valve, angle pattern
The seat material is the same as the body
-G: Graphite packing
-TSW16: The inlet type is Tube socket welding,
The inlet size is ϕ 16mm.
-TSW14: The outlet type is Tube socket welding,
The outlet size is ϕ 14mm.
-S4: Body material is 304SS
-1: The handle is 304SS bar .